

# Selectable Output Horn Strobes, Chime Strobes and Strobes – Wall Mount

TRIGA Life Safety Systems, LLC  
7600 Olde Eight Rd.

Hudson, Ohio 4426-1057

Tel: +1 330-577-5199. Email: info@trigaglobal.com

For use with the following models:

Standard Wall Mount Horn Strobes: **TR-P2RL, TR-P2WL**, P2RL-P, P2WL-P, P2RL-SP, P2WL-SP

Compact Wall Mount Horn Strobes: P2GRL, P2GWL

Standard Wall Mount Chime Strobes: CHSRL, CHSWL

Standard Wall Mount Strobes: **TR-SRL, TR-SWL**, SRL-P, SWL-P, SRL-SP, SWL-CLR-ALERT

Compact Wall Mount Strobes: SGRL, SGWL

**PRODUCT SPECIFICATIONS**

Standard Operating Temperature:	32°F to 120°F (0°C to 49°C)
Humidity Range:	10 to 93% Non-condensing
Strobe Flash Rate	1 flash per second
Nominal Voltage:	Regulated 12VDC or regulated 24DC/FWR
Operating Voltage Range:	8 to 17.5V (12V nominal) or 16 to 33V (24V nominal)
Operating Voltage with MDL3 Sync Module:	8.5 to 17.5V (12V nominal) or 16.5 to 33V (24V nominal)
Input terminal wire gauge:	12 to 18 AWG

**DIMENSIONS FOR PRODUCTS AND ACCESSORIES**

WALL PRODUCTS	Length	Width	Depth
Standard Strobe, Chime Strobe and Horn Strobe	5.6" (143mm)	4.7" (119mm)	1.25" (32mm)
Compact Strobe and Horn Strobe	5.26" (133 mm)	3.46" (88 mm)	1.93 (49 mm)
Standard device with SBBRL/WL Surface Mount Back Box	5.9" (149 mm)	4.9" (125 mm)	1.85" (47 mm)
Compact device with SBBGRL/WL Surface Mount Back Box	5.5" (140 mm)	3.7" (94 mm)	1.6" (39 mm)
<b>NOTE:</b> SBBRL/WL Surface Mount Back Box intended only for standard horn strobes, chime strobes and strobes. SBBGRL/WL Surface Mount Back Box intended for compact horn strobes and strobes.			

**MOUNTING BOX OPTIONS**

Standard 2-Wire Indoor Products:	4" x 4" x 1½", Single Gang, Double Gang, 4" Octagon, SBBRL/WL (wall), SBBGRL/WL (wall)
Compact 2-Wire Indoor Products:	Single Gang, SBBGRL/WL (wall)

**NOTICE:** This manual shall be left with the owner/user of this equipment.

**GENERAL DESCRIPTION**

These notification appliances offer a wide range of audible and visible de-vices for life safety notification. Our 2-wire horn strobes, chime strobes and strobes come with 8 field selectable tone and volume combinations and 7 field selectable candela settings. Intended for indoor applications and approved for wall mount installations only. Available in two attractive mounting designs, standard and compact (horn strobe and strobe only).

These 2-wire horn strobes and strobes are public mode notification appli-ances intended to alert occupants of a life safety event. The 2-wire chime strobe is a private mode notification appliance. The horn is listed to ANSI/UL 464 requirements (public mode) and the strobe is listed to ANSI/UL 1638 (public mode). 2-wire chime strobe is a private mode notification appliance intended to alert trained personnel to investigate a life safety event and take appropriate actions. The chime portion of the chime strobe is listed to ANSI/UL 464 (private mode) and the strobe portion is listed to ANSI/UL 1638 (pri-vate mode).

These notification appliances are designed to be used in either 12 VDC, 24VDC, or 24V FWR (full wave rectified) systems. AV devices can be acti-vated by a compatible Triga fire alarm control panel or power supply. Refer to the appropriate fire alarm control panel manufacturer or power supply for more information.

Wall 2-wire horn strobes, 2-wire chime strobes, and strobes come enabled with System Sensor synchronization protocol which requires connections to a power supply capable of generating the System Sensor synchronization pulses, a FACP NAC output configured to System Sensor synchronization pro-tocol, or the use of MDL3 module to generate the synchronization protocol.

**FIRE ALARM SYSTEM CONSIDERATIONS**

The National Fire Alarm and Signaling Code, NFPA 72, requires that all noti-fication appliances, used for building evacuation installed after July 1, 1996, produce temporal coded signals. Signals other than those used for evacuation purposes do not have to produce the temporal coded signal. Triga recom-mends spacing notification appliances in compliance with NFPA 72.

**SYSTEM DESIGN**

The system designer must make sure that the total current draw by the devices on the loop does not exceed the current capability of the panel supply, and that the last device on the circuit is operated within its rated voltage. The cur-rent draw information for making these calculations can be found in the tables within the manual.

When calculating the voltage available to the last device, it is necessary to consider the voltage due to the resistance of the wire. The thicker the wire, the smaller the voltage drop. Wire resistance tables can be obtained from electri-cal handbooks. Note that if Class A wiring is installed, the wire length may be up to twice as long as it would be for circuits that are not fault tolerant. The total number of strobes on a single NAC must not exceed 69 for 24 volt applications.

**AVAILABLE TONES**

These models offer a wide variety of tones for your life safety needs, including temporal 3 pattern (½ second on, ½ second off, ½ second on, ½ second off, ½ second on, 1½ off and repeat) which is specified by ANSI and NFPA 72 for standard emergency evacuation signaling.

To select the tone, turn the rotary switch on the back of the product to the desired setting. (See Figure 1.)

Available horn settings can be found in Table 1. Available chime settings can be found in Table 2.

**TABLE 1. HORN TONES**

Pos	Tone	Volume Setting
1	Temporal	High
2	Temporal	Low
3	Non-Temporal	High
4	Non-Temporal	Low
5	3.1 KHz Temporal	High
6	3.1 KHz Temporal	Low
7	3.1 KHz Non-Temporal	High
8	3.1 KHz Non-Temporal	Low

**TABLE 2. CHIME TONES**

Pos	Tone	Volume Setting
1	1 Second Chime	High
2	1 Second Chime	Low
3	¼ Second Chime	High
4	¼ Second Chime	Low
5	Temporal Chime	High
6	Temporal Chime	Low
7	5 Second Whoop	High
8	5 Second Whoop	Low

**AVAILABLE CANDELA SETTINGS**

These models offer a wide range of candela settings for your life safety needs. In order to select your candela output, adjust the slide switch on the rear of the product to the desired candela setting on the selector switch. (See Figure 2.)

The candela setting can also be verified by looking into the small window on the front of the unit. See Table 3 for candela settings for wall products. All products meet the light output profiles specified in the appropriate UL Standards. (See Figures 3 and 4.)

**CURRENT DRAW AND AUDIBILITY RATINGS**

For the strobe, the current draw for each setting is listed in Table 3. For the horn strobe, the current draw and audibility settings are listed in Table 4. For the chime strobe, the current draw and audibility settings are listed in Table 5.

**FIGURE 1. AUDIO SELECTOR**

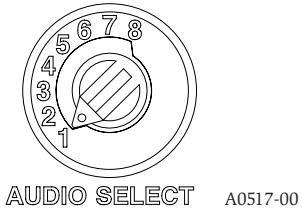

**FIGURE 2. CANDELA SELECTOR**

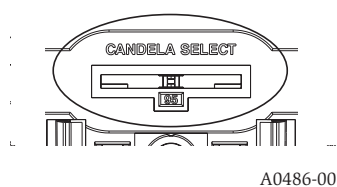

**TABLE 3. WALL-MOUNT STROBE CURRENT DRAW (mA)**

Candela	8-17.5 Volts		16-33 Volts	
	DC	DC	FWR	
15	88	43	60	
30	143	63	83	
75	-	107	136	
95	-	121	155	
110	-	148	179	
135	-	172	209	
185	-	222	257	

**NOTE:** Products set at 15 and 30 candela automatically work on either 12V or 24V power supplies. The products are not listed for 12V DC operation when set to any other candela settings.

**FIGURE 3. LIGHT OUTPUT – HORIZONTAL DISPERSION**

Degrees*	Percent of Rating
0	100
5-25	90
30-45	75
50	55
55	45
60	40
65	35
70	35
75	30
80	30
85	25
90	25
Compound 45 to the left	24
Compound 45 to the right	24

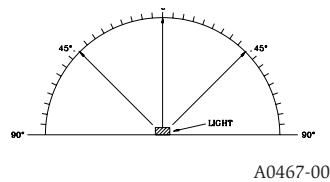

**FIGURE 4. VERTICAL DISPERSION – WALL TO FLOOR**

Degrees*	Percent of Rating
0	100
5-30	90
35	65
40	46
45	34
50	27
55	22
60	18
65	16
70	15
75	13
80	12
85	12
90	12

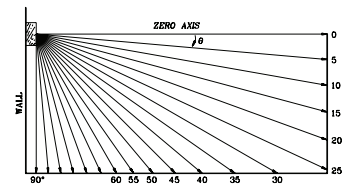

\*Tolerance of ± 1 degree is permitted.

**WIRING AND MOUNTING**

All wiring must be installed in compliance with the National Electric Code and the local codes as well as the authority having jurisdiction. Wiring must not be of such length or wire size which would cause the notification appliance to operate outside of its published specifications. Improper connections can prevent the system from alerting occupants in the event of an emergency.

Wire sizes up to 12 AWG (2.5 mm<sup>2</sup>) may be used with the mounting plate. The mounting plate ships with the terminals set for 12 AWG wiring.

Make wire connections by stripping about 3/8" of insulation from the end of the wire. Then slide the bare end of the wire under the appropriate clamping plate and tighten the clamping plate screw.

We provide a wire STRIP guide. See Figure 5 for wiring terminals and strip guide reference.

**CAUTION**

Factory finish should not be altered: Do not paint!

**CAUTION**

Do not over tighten mounting plate screws; this may cause mounting plate to flex.

**FIGURE 5. WIRING TERMINALS, SHORTING SPRING, AND STRIP GUIDE**

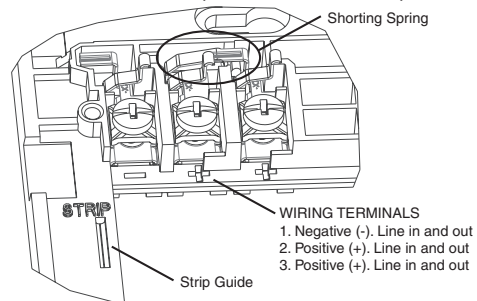

**SYSTEM WIRING**

The 2-wire horn strobe, chime strobe and strobe only require two wires for power and supervision. (See Figure 6.) Please consult your FACP manufacturer or power supply manufacturer for specific wiring configurations and special cases.

**FIGURE 6. 2-WIRE CIRCUIT**

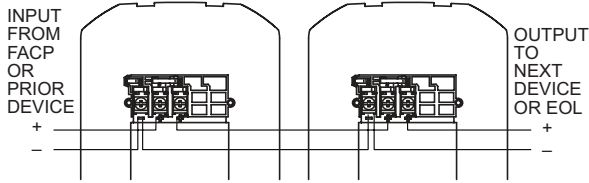

A0367-02

**SHORTING SPRING FEATURE**

These notification appliances come with a shorting spring that is provided between terminals 2 and 3 of the mounting plate to enable system continuity checks after the system has been wired, but prior to installation of the final product. (See Figure 5.) This spring will automatically disengage when the product is installed, to enable supervision of the final system.

**MOUNTING AND REMOVING APPLIANCE**

1. Attach mounting plate to junction box. (See Figures 7 and 8.)
2. Connect field wiring according to terminal designations. (See Figures 5 and 6.)
3. If the product is not to be installed at this point, use the protective dust cover to prevent contamination of the wiring terminals on the mounting plate.
4. To attach product to mounting plate:
  - a. Remove the protective dust cover.
  - b. Hook the tabs on the top of the product housing into the grooves on mounting plate.

- c. Pivot the product into position to engage the terminals on the mounting plate. Make sure that the tabs on the back of the product housing fully engage with the mounting plate.
- d. Hold product in place with one hand, and secure product by tightening the single mounting screw in the front of the product housing.

**INSTALLING A SURFACE MOUNT BACK BOX**

1. The surface mount back box may be secured directly to the wall or ceiling. Use of grounding bracket with ground screw is optional. (See Figures 9 and 10.)
  2. The wall mount back box must be mounted with the up arrow pointing up. (See Figure 12.)
  3. Threaded knockout holes are provided for the sides of the box for 3/4 inch and 1/2 inch conduit adapter. Knockout holes in the back of the box can be used for 3/4 inch and 1/2 inch rear entry.
  4. To remove the 3/4 inch knockout, place the blade of a flat-head screwdriver along the outer edge and work your way around the knockout as you strike the screwdriver. (See Figure 13.)
- NOTE: Use caution not to strike the knockout near the top edge of the surface mount back box.**
5. V500 and V700 raceway knockouts are also provided. Use V500 for low profile applications and V700 for high profile applications.
  6. To remove the knockout, turn pliers up. (See Figure 13.)

**TABLE 4. WALL-MOUNT HORN STROBE CURRENT DRAW (mA) AND SOUND OUTPUT (dBA)**

Pos	Tone	Volume Setting	Current draw (mA)																Sound Output (dBA)		
			8-17.5 VDC		16-33 VDC						16-33 FWR						8-17.5 V		16-33 V		
			15	30	15	30	75	95	110	135	185	15	30	75	95	110	135	185	DC	DC	FWR
1	Temporal	High	98	158	54	74	121	142	162	196	245	83	107	156	177	198	234	287	84	89	89
2	Temporal	Low	93	154	44	65	111	133	157	184	235	68	91	145	165	185	223	271	75	83	83
3	Non-Temporal	High	106	166	73	94	139	160	182	211	262	111	135	185	207	230	264	316	85	90	90
4	Non-Temporal	Low	93	156	51	71	119	139	162	190	239	79	104	157	175	197	235	283	76	84	84
5	3.1 KHz Temporal	High	93	156	53	73	119	140	164	190	242	81	105	155	177	196	234	284	83	88	88
6	3.1 KHz Temporal	Low	91	154	45	66	112	133	160	185	235	68	90	145	166	186	222	276	76	82	82
7	3.1 KHz Non-Temporal	High	99	162	69	90	135	157	175	208	261	104	131	177	204	230	264	326	84	89	89
8	3.1 KHz Non-Temporal	Low	93	156	52	72	119	138	162	192	242	77	102	156	177	199	234	291	77	83	83

**NOTE:** Products set at 15 and 30 candela automatically work on either 12V or 24V power supplies. The products are not listed for 12VDC operation when set to any other candela settings.

**TABLE 5. WALL MOUNT CHIME STROBE CURRENT DRAW (mA) AND SOUND OUTPUT (dBA)**

Pos	Chime Tone	Volume Setting	Current draw (mA)																Sound Output (dBA)		
			8-17.5 VDC		16-33 VDC						16-33 FWR						8-17.5 V		16-33 V		
			15	30	15	30	75	95	110	135	185	15	30	75	95	110	135	185	DC	DC	FWR
1	1 Second	High	90	154	51	71	116	136	161	202	242	70	90	160	176	197	233	275	61	62	62
2	1 Second	Low	89	154	50	70	115	136	154	199	238	67	88	158	175	191	232	271	56	55	55
3	1/4 Second	High	90	154	52	72	117	137	168	201	242	69	93	159	175	198	233	272	67	70	70
4	1/4 Second	Low	89	153	49	70	115	136	165	199	241	68	93	154	169	196	232	270	61	61	61
5	Temporal	High	88	153	49	69	112	137	168	201	246	65	90	145	170	189	228	283	64	66	66
6	Temporal	Low	88	152	47	68	111	136	167	196	241	64	89	142	170	188	219	282	59	60	60
7	5 Second Whoop	High	91	154	52	70	113	132	176	206	243	70	93	145	168	187	223	278	76	78	78
8	5 Second Whoop	Low	87	149	46	66	108	130	170	202	240	62	84	137	159	180	216	272	62	64	64

**NOTE:** Products set at 15 and 30 candela automatically work on either 12V or 24V power supplies. The products are not listed for 12VDC operation when set to any other candela settings.

**FIGURES 7 AND 8. MOUNTING**

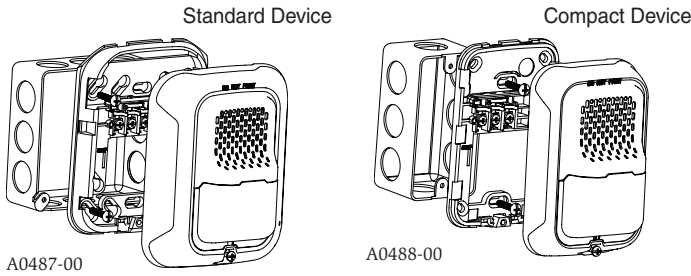

**FIGURES 9 AND 10. SURFACE MOUNTING**

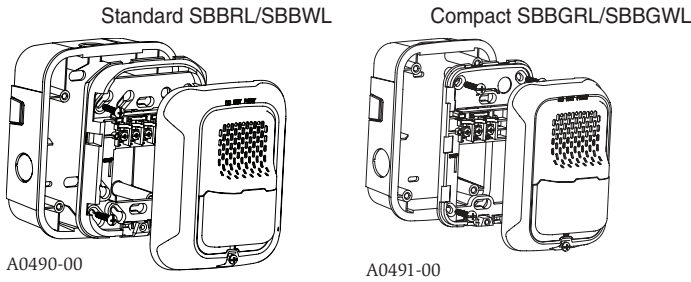

**TAMPER SCREW**

For tamper resistance, the standard captive screw may be replaced with a Torx screw, ordered separately.

1. To remove the captive screw, back out the screw and apply pressure to the back of the screw until it disengages from the housing. Replace with Torx screw. (See Figure 11.)

**FIGURE 11. TAMPER SCREW**

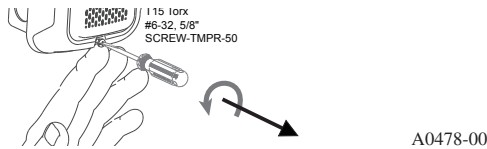

**FIGURE 12. SURFACE MOUNT BACK BOX UP ARROW**

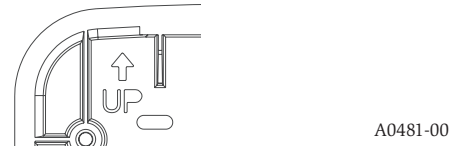

**FIGURE 13. KNOCKOUT AND V500/V700 REMOVAL FOR SURFACE MOUNT BACK BOX**

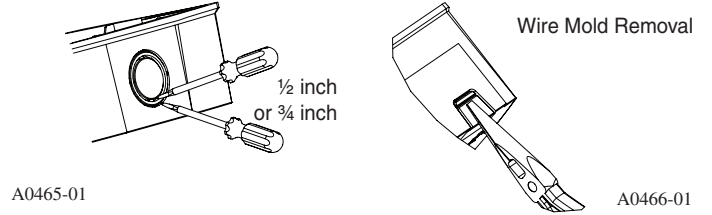

**FCC STATEMENT**

These Strobes and Horn/Strobes have been tested and found to comply with the limits for a Class B digital device, pursuant to part 15 of the FCC Rules. These limits are designed to provide reasonable protection against harmful interference when the equipment is operated in a commercial environment. This equipment generates, uses, and can radiate radio frequency energy and, if not

installed and used in accordance with the instruction manual, may cause harmful interference to radio communications. Operation of this equipment in a residential area is likely to cause harmful interference in which case the user will be required to correct the interference at his own expense.

**WARNING**

**THE LIMITATIONS OF HORN/STROBES**

**The horn and/or strobe will not work without power.** The horn/strobe gets its power from the fire/security panel monitoring the alarm system. If power is cut off for any reason, the horn/strobe will not provide the desired audio or visual warning.

**The horn may not be heard.** The loudness of the horn meets (or exceeds) current Underwriters Laboratories' standards. However, the horn may not alert a sound sleeper or one who has recently used drugs or has been drinking alcoholic beverages. The horn may not be heard if it is placed on a different floor from the person in hazard or if placed too far away to be heard over the ambient noise such as traffic, air conditioners, machinery or music appliances that may prevent alert persons from hearing the alarm. The horn may not be heard by persons who are hearing impaired.

**NOTE:** Strobes must be powered continuously for horn operation.

**The signal strobe may not be seen.** The electronic visual warning

signal uses an extremely reliable xenon flash tube. It flashes at least once every second. The strobe must not be installed in direct sunlight or areas of high light intensity (over 60 foot candles) where the visual flash might be disregarded or not seen. The strobe may not be seen by the visually impaired.

**The signal strobe may cause seizures.** Individuals who have positive photoic response to visual stimuli with seizures, such as persons with epilepsy, should avoid prolonged exposure to environments in which strobe signals, including this strobe, are activated.

**The signal strobe cannot operate from coded power supplies.** Coded power supplies produce interrupted power. The strobe must have an uninterrupted source of power in order to operate correctly. Triga recommends that the horn and signal strobe always be used in combination so that the risks from any of the above limitations are minimized.