

TR-B200SR-WH, TR-B200SR-IV Intelligent Sounder Base

TRIGA Life Safety Systems, LLC
7600 Olde Eight Rd.
Hudson, Ohio 4426-1057
Tel: +1 330-577-5199. Email: info@trigaglobal.com

Specifications

Base Diameter:	6.875" (17.46 cm)
Base Height (less sensor):	2.0" (5.08 cm)
Weight:	0.50 lb. (227 gm)
Operating Temperature Range:	Refer to the applicable sensor's operating temperature range provided in the sensor's installation manual.
Operating Humidity Range:	10% to 93% relative humidity (non-condensing)

External Supply Electrical Ratings

External Supply Voltage:	16 to 33 VDC (VFWR)
Standby Current:	500 µA maximum
Alarm Current:	35 mA maximum

SLC Electrical Ratings

SLC Operating Voltage:	15 to 32 VDC
SLC Standby Current:	300 µA maximum

Sound Output

Greater than 85 dBA minimum measured in a UL reverberant room at 10 feet (3.1m), 24 Volts (in continuous tone)

BEFORE INSTALLING

Read System Sensor's *Applications Guide for System Smoke Detectors* (SPAG91), which provides detailed information on sensor spacing, placement, zoning, wiring, and special applications. This manual is available online at www.systemsensor.com. NFPA 72 and NEMA guidelines should be observed.

NOTICE: This manual should be left with the owner/user of this equipment.

IMPORTANT: The detector used with this base must be tested and maintained regularly following NFPA 72 requirements. The detector should be cleaned at least once a year.

GENERAL DESCRIPTION

The TR-B200SR-WH and TR-B200SR-IV sounder bases are used with addressable detector heads. Refer to the appropriate manual for more information on sensors.

The TR-B200SR-WH and TR-B200SR-IV sounder bases were designed specifically to meet the needs of dwelling unit applications. It offers maximum flexibility in configuration and operation to meet or exceed the requirements of UL268 and UL464.

The sounder base is capable of producing either the distinctive three-pulse temporal pattern (ANSI Temporal 3) fire alarm signal now required by NFPA 72 for commercial and residential applications or a continuous tone by simply removing the included jumper from the device.

The sounder base is intended for use with intelligent systems. The sounder base requires an external 24 VDC power supply. The connections for the external power supply and the communication loop are isolated to prevent electrical interaction between them. Refer to the panel manual for maximum allowable number of units per loop.

NOTE: For NFPA72 Installations, the Temporal 3 tone should be used for public mode evacuation.

NOTE: When not used as a supplementary evacuation system, the external 24 VDC supply shall be treated as a component of the main power supply system and shall fall under the requirements of the main power supply system per NFPA 72.

WIRING GUIDELINES

All wiring must be installed in compliance with the National Electrical Code and the local codes having jurisdiction and must not be of such length or wire size which would cause the base to operate outside of its published specifications. The conductors used to connect smoke sensors to control panels and accessory devices should be color coded to reduce the likelihood of wiring errors. Improper connections can prevent a system from responding properly in the event of a fire.

Wire sizes up to 12 AWG (2.5 mm²) may be used with the base. The sounder base will be shipped with the screw terminals set for 14 AWG wiring. If 12 AWG wire is to be used, back out the screws to allow the wire to fit beneath the clamping plates. For best system performance, the power (+ and -) wires and the communication circuit wires should be twisted pair or shielded cable installed in a separate grounded conduit to protect the communication loop from electrical interference.

Make wire connections by stripping about 3/8" (10 mm) of insulation from the end of the wire. Then, slide the bare end of the wire under the appropriate clamping plate (See Figure 1), and tighten the clamping plate screw. Do NOT loop the wire under the clamping plate. (See Figure 2.) The wiring diagram for a typical 2-wire intelligent system is shown in Figure 5.

CAUTION

For system monitoring - for terminals 4 and 5, do not use looped wire under terminals. Break wire run as shown in Figure 2 to provide monitoring of connections.

FIGURE 1.

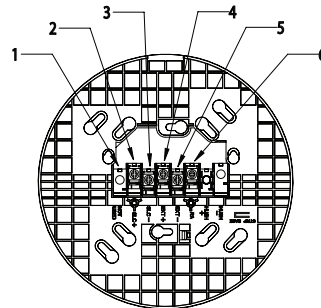

C0471-07

FIGURE 2.

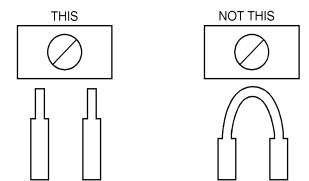

C0473-00

TR-B200SR-WH/TR-B200SR-IV TERMINALS

No.	Function
1.	Not Used
2.	Positive (+) Comm. Line In and Out
3.	Negative (-) Comm. Line In and Out
4.	External Supply Positive (+)
5.	External Supply Negative (-)
6.	Sounder Base Interconnect

MOUNTING

Mount the TR-B200SR-WH/TR-B200SR-IV mounting plate directly to an electrical box. The plate will mount directly to 4" (10.2cm) square (with and without plaster ring), 4" (10.2cm) octagon, 3 1/2" (8.9 cm) octagon, single gang or double gang junction boxes.

1. Connect field wiring to terminals, as shown in Figure 1 and 2.
2. Attach the mounting plate to the junction box as shown in Figure 3.
3. To mount the sounder base, hook the tab on the sounder base to the groove on the mounting plate.
4. Then, swing the sounder base into position to engage the pins on the product with the terminals on the mounting plate.
5. Secure the sounder base by tightening the mounting screws.
6. Install a compatible smoke sensor as described in the installation manual for the sensor.

CAUTION

Do not over tighten mounting plate screws; this may cause mounting plate to flex.

FIGURE 3. MOUNTING

Location of jumper—
remove to enable
continuous tone

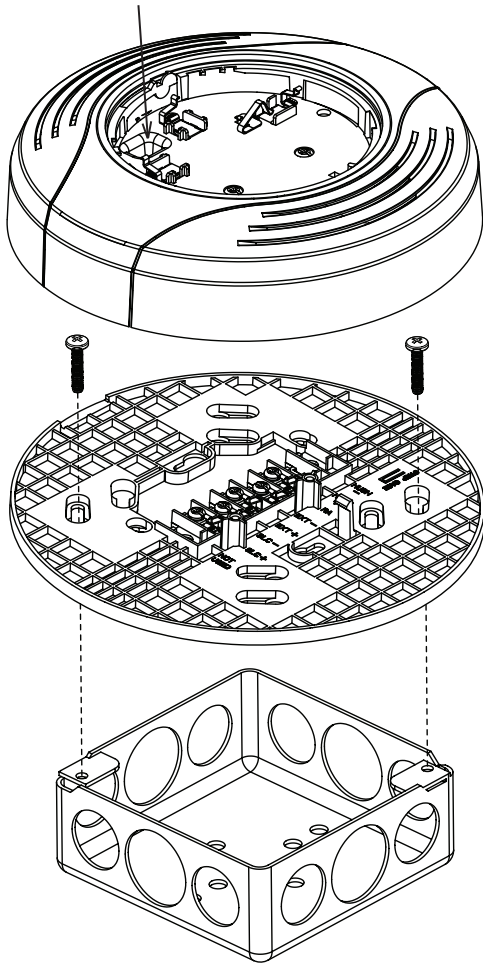

TAMPER RESISTANT FEATURE

NOTE: Do not use the tamper-resist feature if the removal tool is to be used. This detector base includes a tamper-resist feature that prevents its removal from the base without the use of a tool. To activate this feature, break the tab from the detector base as shown in Figure 4A. Then, install the detector. To remove the detector from the base once the tamper-resist feature has been activated, insert a small-bladed screwdriver into the slot from the top and press down on the lever. (See Figure 4B). This allows the detector to be rotated counterclockwise for removal. The tamper-resist feature can be defeated by breaking and removing the plastic lever from the base. However, this prevents the feature from being used again.

TESTING AND MAINTENANCE

Sensors and bases must be tested after installation and as an integral part of a periodic maintenance program. Test the TR-B200SR-WH/TR-B200SR-IV as follows:

NOTE: Before testing, notify the proper authorities that the smoke sensor system is undergoing maintenance and, therefore, will be temporarily out of service. Disable the system undergoing maintenance to prevent unwanted alarms.

1. If configured as in Figure 5 and 6, reverse the polarity of the external 24VDC supply. If configured as in Figure 6, turn on the Intelligent Relay Module. All TR-B200SR-WH/TR-B200SR-IV bases on the loop should sound.
2. Latch the sensor LED on from the control panel. That individual sensor's TR-B200SR-WH/TR-B200SR-IV should sound.

When performing maintenance on connected smoke sensors, carefully note the location and address of each removed sensor.

FIGURE 4A. ACTIVATING THE TAMPER-RESIST FEATURE

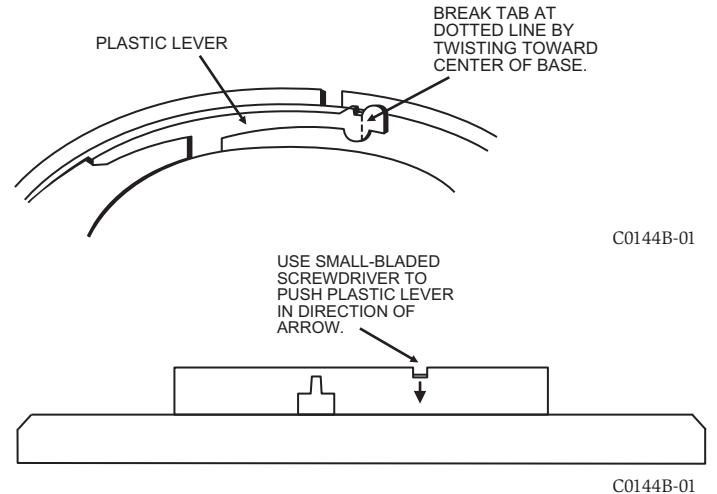
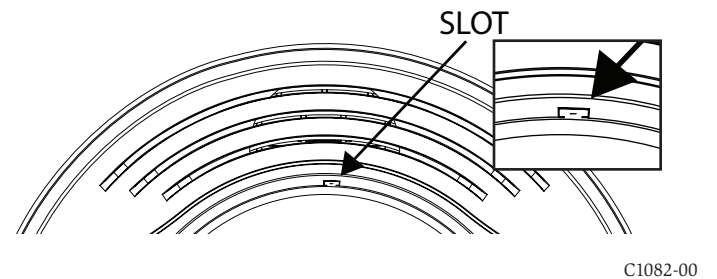

FIGURE 4B. REMOVING THE DETECTOR HEAD FROM THE BASE



**FIGURE 5. WIRING DIAGRAM
DETECTOR ACTIVATES SOUNDER BASE(S) - (COMPLIES WITH UL268)**

UL has approved grouping for up to six TR-B200SR-WH/TR-B200SR-IV sounder bases. When wired as a group, any detector in the group that has been activated by the panel will cause other TR-B200SR-WH/TR-B200SR-IV units in the group to sound. This type of "local" grouping is accomplished by wiring the grouped devices together using terminal 6, Sounder Base Interconnect, as shown in the diagram. Some Fire Alarm Control Panels (FACP) support the grouping of sounder bases via software in lieu of the Sounder Base Interconnect.

NOTE: A local grouping of horns via the sounder base interconnect is not supervised, therefore the groups can only be used as a supplementary evacuation system. It is not acceptable to group horns via the sounder base interconnect for primary alarm signaling. Sounder bases which are grouped via software are not subject to this limitation and may be used as part of the primary alarm signaling.

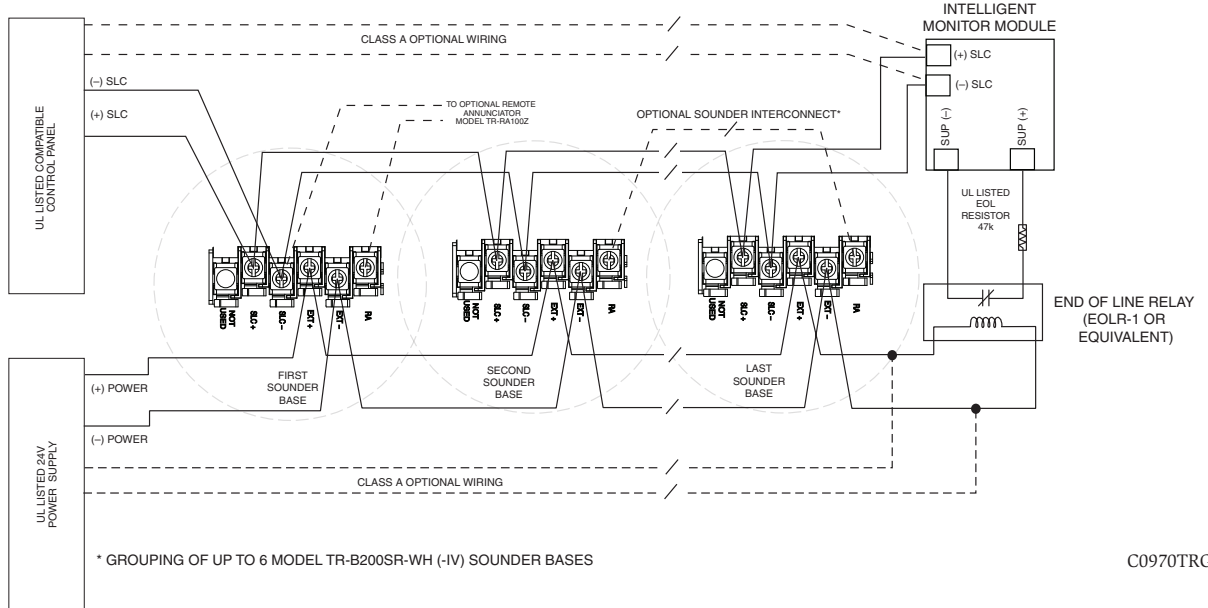

C0970TRG-22

**FIGURE 6. WIRING DIAGRAM
DETECTOR ACTIVATES SOUNDER BASE(S);
INTELLIGENT RELAY MODULE ACTIVATES ALL SOUNDER BASES - (COMPLIES WITH UL 268 AND UL 464)**

UL has approved grouping for up to six TR-B200SR-WH/TR-B200SR-IV sounder bases. When wired as a group, any detector in the group that has been activated by the panel will cause other TR-B200SR-WH/TR-B200SR-IV units in the group to sound. This type of "local" grouping is accomplished by wiring the grouped devices together using terminal 6, Sounder Base Interconnect, as shown in the diagram. Some Fire Alarm Control Panels support the grouping of sounder bases via software in lieu of the Sounder Base Interconnect.

NOTE: A local grouping of horns via the sounder base interconnect is not supervised, therefore the groups can only be used as a supplementary evacuation system. It is not acceptable to group horns via the sounder base interconnect for primary alarm signaling. Sounder bases which are grouped via software are not subject to this limitation and may be used as part of the primary alarm signaling.

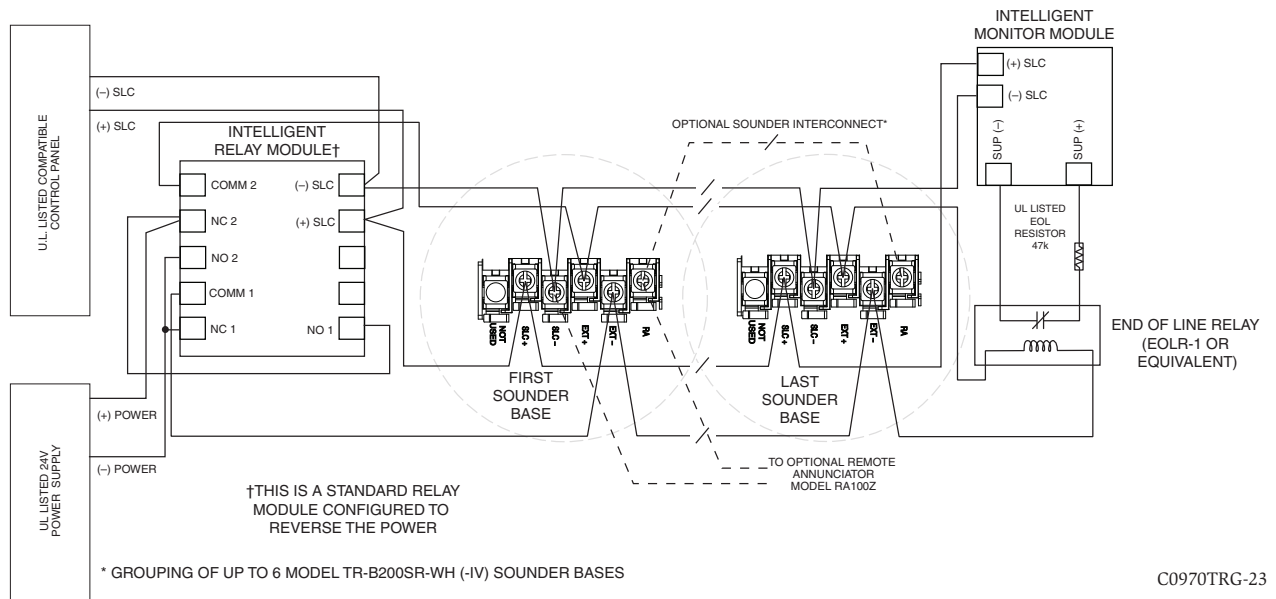

C0970TRG-23

