

Selectable Output Speaker Strobes

– Wall and Ceiling Mount

TRIGA Life Safety Systems, LLC
7600 Olde Eight Rd.

Hudson, Ohio 4426-1057

Tel: +1 330-577-5199. Email: info@trigaglobal.com

For use with the following models:

Wall Speakers: **TR-SPSRL, TR-SPSWL, TR-SPSRL-P, TR-SPSWL-P, SPSRL-SP, SPSWL-CLR-ALERT**

Ceiling Speakers: **TR-SPSCRL, TR-SPSCWL, TR-SPSCWL-P, SPSCWL-SP, SPSCWL-CLR-ALERT**

PRODUCT SPECIFICATIONS

| | |
|--|---|
| Standard Operating Temperature: | 32°F to 120°F (0°C to 49°C) |
| Humidity Range: | 10 to 93% Non-condensing |
| Nominal Voltage (speakers): | 25 Volts or 70.7 Volts |
| Maximum Supervisory Voltage: | 50 VDC |
| Speaker Frequency Range: | 400 – 4000 Hz |
| Power Settings: | ¼, ½, 1, 2 Watts |
| Input terminal wire gauge: | 12 to 18 AWG |
| Strobe Flash Rate: | 1 flash per second |
| Nominal Voltage (strobes): | Regulated 12VDC, regulated 24VDC or FWR |
| Operating Voltage Range (includes fire alarm panels with built in sync): | 8 to 17.5V (12V nominal) or 16 to 33V (24V nominal) |
| Operating Voltage with MDL3 Sync Module: | 8.5 to 17.5V (12V nominal) or 16.5 to 33V (24V nominal) |

| DIMENSIONS FOR PRODUCTS AND ACCESSORIES | | | |
|--|----------------|----------------|-----------------|
| WALL PRODUCTS | Length | Width | Depth |
| Wall Speaker Strobe | 6.5" (165 mm) | 5.00" (127 mm) | 2.30" (58.4 mm) |
| CEILING PRODUCTS | Length | Width | Depth |
| Ceiling Speaker Strobe | 6.8" (173 mm) | N/A | 2.87" (73mm) |
| WALL SURFACE MOUNT BACK BOX | Length | Width | Depth |
| Speaker Strobe with SBBSPL/WL Surface Mount Back Box | 6.62" (168mm) | 5.12" (130 mm) | 2.30" (58.4 mm) |
| CEILING SURFACE MOUNT BACK BOX | Diameter | | Depth |
| Speaker Strobe with SBBCL/WL Surface Mount Back Box | 6.92" (176 mm) | | 5.37" (116mm) |

| MOUNTING BOX OPTIONS |
|---|
| SPEAKER STROBES |
| SBBSPL/WL (wall), SBBCL/WL (ceiling), 4" x 4" x 2 1/8" or deeper (When using 12AWG, 14 AWG, or adding extra wires in the box, a deeper box or extension ring is recommended.) |

NOTICE: This manual shall be left with the owner/user of this equipment.

GENERAL DESCRIPTION

These notification appliances offer a wide range of audible and visible devices for life safety notification. Our indoor speaker strobes come with 7 field select-able candela setting. The strobe portion is designed to be used in 12 VDC, 24VDC, or 24V FWR (full wave rectified) systems. The speaker is designed to be used at either 25 or 70.7 volts, and operate at any one of four input power levels. Our speaker strobes are suitable for dry and damp environments. With its low total harmonic distortion, the SPL series offers high fidelity sound output.

These speakers strobes are public mode notification appliances intended to alert occupants of a life safety event. The speaker is listed to ANSI/UL 1480 (public mode) and the strobe is listed to ANSI UL 1638 (public mode).

FIRE ALARM SYSTEM CONSIDERATIONS

Triga also recommends installing fire alarm speakers in compliance with NFPA 72, ANSI/UL 1480 and NEC 760.

SYSTEM DESIGN

The system designer must make sure that the total current drawn by the devices on the loop does not exceed the current capability of the panel supply, and that the last device on the circuit is operated within its rated voltage. The current draw information for making these calculations can be found in the tables within this manual.

When calculating the voltage for the last device, it is necessary to consider the voltage drop due to the resistance of the wire. The thicker the wire, the smaller the voltage drop. Note that if Class A wiring is installed, the wire length may be up to twice as long as it would be circuits that are not fault tolerant. The total number of strobes on a single NAC must not exceed 69 for 24 volt applications.

AVAILABLE CANDELA SETTINGS

These models offer a wide range of candela settings for your life safety needs. In order to select your candela output, adjust the slide switch on the rear of the product to the desired candela setting on the selector switch. (See Figure 1.)

The candela setting can also be verified by looking into the small window on the front of the unit. See Tables 1 and 2 for candela settings for wall and ceiling products. All products meet the light output profiles specified in the appropriate UL Standards. (See Figures 2–4.)

FIGURE 1. CANDELA SELECTOR

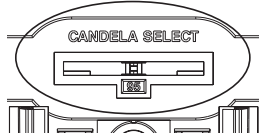

A0486-00

CURRENT DRAW AND AUDIBILITY RATINGS

For the strobe, the current draw for each setting is listed in Tables 1 and 2.

TABLE 1. WALL-MOUNT STROBE CURRENT DRAW (mA)

| Candela | 8-17.5 Volts | | 16-33 Volts | |
|---------|--------------|-----|-------------|-----|
| | DC | FWR | DC | FWR |
| 15 | 88 | 60 | 43 | 60 |
| 30 | 143 | 83 | 63 | 83 |
| 75 | - | 136 | 107 | 136 |
| 95 | - | 155 | 121 | 155 |
| 110 | - | 179 | 148 | 179 |
| 135 | - | 209 | 172 | 209 |
| 185 | - | 257 | 222 | 257 |

NOTE: Products set at 15 and 30 candela automatically work on either 12V or 24V power supplies. The products are not listed for 12V DC operation when set to any other candela settings.

TABLE 2. CEILING-MOUNT STROBE CURRENT DRAW (mA)

| Candela | 8-17.5 Volts | | 16-33 Volts | |
|---------|--------------|-----|-------------|-----|
| | DC | FWR | DC | FWR |
| 15 | 87 | 60 | 41 | 60 |
| 30 | 153 | 86 | 63 | 86 |
| 75 | - | 142 | 111 | 142 |
| 95 | - | 164 | 134 | 164 |
| 115 | - | 191 | 158 | 191 |
| 150 | - | 228 | 189 | 228 |
| 177 | - | 264 | 226 | 264 |

NOTE: Products set at 15 and 30 candela automatically work on either 12V or 24V power supplies. The products are not listed for 12V DC operation when set to any other candela settings.

FIGURE 2. WALL LIGHT OUTPUT – HORIZONTAL DISPERSION

| Degrees* | Percent of Rating |
|--------------------------|-------------------|
| 0 | 100 |
| 5-25 | 90 |
| 30-45 | 75 |
| 50 | 55 |
| 55 | 45 |
| 60 | 40 |
| 65 | 35 |
| 70 | 35 |
| 75 | 30 |
| 80 | 30 |
| 85 | 25 |
| 90 | 25 |
| Compound 45 to the left | 24 |
| Compound 45 to the right | 24 |

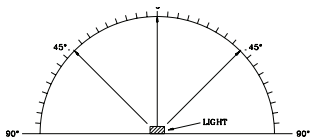

A0467-00

FIGURE 3. VERTICAL DISPERSION, WALL TO FLOOR

| Degrees* | Percent of Rating |
|----------|-------------------|
| 0 | 100 |
| 5-30 | 90 |
| 35 | 65 |
| 40 | 46 |
| 45 | 34 |
| 50 | 27 |
| 55 | 22 |
| 60 | 18 |
| 65 | 16 |
| 70 | 15 |
| 75 | 13 |
| 80 | 12 |
| 85 | 12 |
| 90 | 12 |

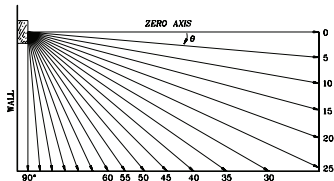

A0469-00

*Tolerance of ± 1 degree is permitted.

FIGURE 4. LIGHT OUTPUT - VERTICAL DISPERSION, CEILING TO WALLS TO FLOOR

| Degrees* | Percent of Rating |
|----------|-------------------|
| 0 | 100 |
| 5-25 | 90 |
| 30-45 | 75 |
| 50 | 55 |
| 60 | 45 |
| 65 | 35 |
| 70 | 35 |
| 75 | 30 |
| 80 | 30 |
| 85 | 25 |
| 90 | 25 |

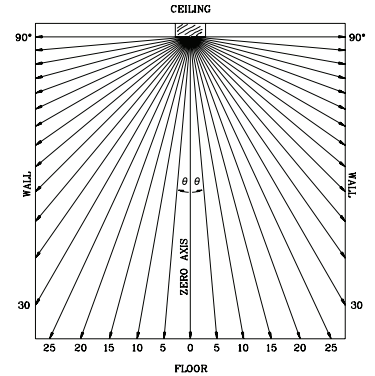

A0468-00

WIRING AND MOUNTING

All wiring must be installed in compliance with the National Electric Code and the local codes as well as the authority having jurisdiction. Wiring must not be of such length or wire size which would cause the notification appliance to operate outside of its published specifications. Improper connections can prevent the system from alerting occupants in the event of an emergency.

Wire sizes up to 12 AWG (2.5 mm²) may be used with the mounting plate. The mounting plate ships with the terminals set for 12 AWG wiring.

Make wire connections by stripping about 3/8" of insulation from the end of the wire. Then slide the bare end of the wire under the appropriate clamping plate and tighten the clamping plate screw.

See Figure 5 for wiring terminals and strip guide reference.

1. Connect the speaker. (See Figure 5.)
2. There are two rotary switches on the back of the product. The first switch is used to select either 25 or 70.7 volts input and the second switch is used to select the input power of 1/4, 1/2, 1 or 2 watts. (See Figure 6.)

FIGURE 5. WIRING DIAGRAM AND WIRING TERMINALS

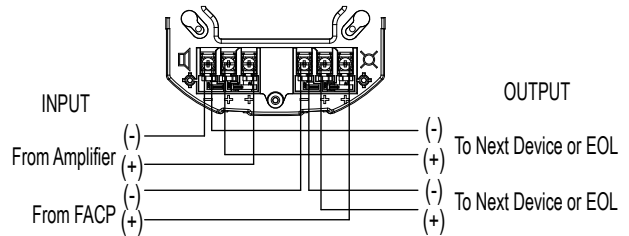

A0519-01

| | |
|---|---|
| <p>Wiring Terminals</p> <ol style="list-style-type: none"> 1. Negative (-). Line in and out 2. Positive (+). Line in and out 3. Positive (+). Line in and out | <p>NOTE: Do not loop electrical wiring under terminal screws. Wires connecting the device to the control panel must be broken at the device terminal connection in order to maintain electrical supervision.</p> |
|---|---|

FIGURE 6. SPEAKER WATTAGE AND VOLTAGE SETTINGS

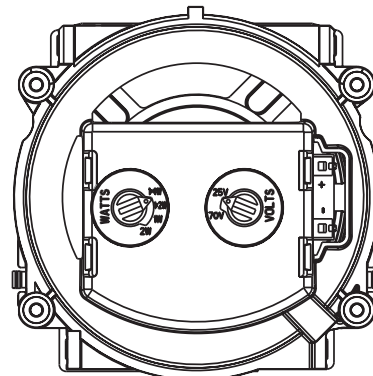

A0419-01

SHORTING SPRING FEATURE

These notification appliances come with a shorting spring that is provided between terminals 2 and 3 of the mounting plate to enable system continuity checks after the system has been wired, but prior to installation of the final product. (See Figure 7.) This spring will automatically disengage when the product is installed, to enable supervision of the final system.

FIGURE 7. SHORTING SPRING

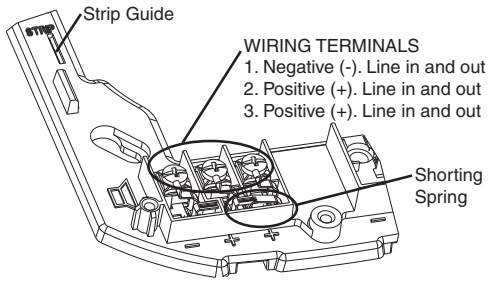

A0499-02

AVAILABLE POWER SETTINGS

These models offer a wide range of power settings for your life safety needs, including ¼, ½, 1, and 2W.

Sound levels data per UL 1480 can be found in Table 3.

TABLE 3. SOUND LEVELS FOR EACH TRANSFORMER POWER SETTING

| Setting | UL Reverberant (dBA @10 ft) | UL Anechoic (dBA @10 ft) |
|---------|-----------------------------|--------------------------|
| ¼ W | 77 | 77 |
| ½ W | 80 | 80 |
| 1 W | 83 | 83 |
| 2 W | 86 | 86 |

CAUTION

Signal levels exceeding 130% rated signal voltage can damage the speaker. Consequently, an incorrect tap connection may cause speaker damage. This means that if a 25V tap is selected when a 70.7V amplifier is being used, speaker damage may result. Therefore, be sure to select the proper taps for the amplifier voltage/input power level combination being used.

MOUNTING AND REMOVING APPLIANCE

1. Attach mounting plate to junction box using two of the provided Philips head screws. (See Figures 8 and 9.)
2. Connect field wiring according to terminal designations. (See Figure 5.)
3. If the product is not to be installed at this point, use the protective dust cover to prevent contamination of the wiring terminals on the mounting plate.
4. To attach product to mounting plate:
 - a. Remove the protective dust cover.
 - b. Hook the tabs on the top of the product housing into the grooves on mounting plate.
 - c. Pivot the product into position to engage the terminals on the mounting plate. Make sure that the tabs on the back of the product housing fully engage with the mounting plate.
 - d. Hold product in place with one hand, and secure product by tightening the single mounting screw in the front of the product housing.

Ceiling Models only: To remove product from the mounting plate, press the locking button after loosening the captive mounting screw.

CAUTION

The “hold in place” snaps are not intended to secure the product to the back box. The product must be secured to the back box using the screws provided.

CAUTION

Factory finish should not be altered: Do not paint!

CAUTION

Do not over tighten mounting plate screws; this may cause mounting plate to flex.

FIGURE 8. WALL SPEAKER/STROBE

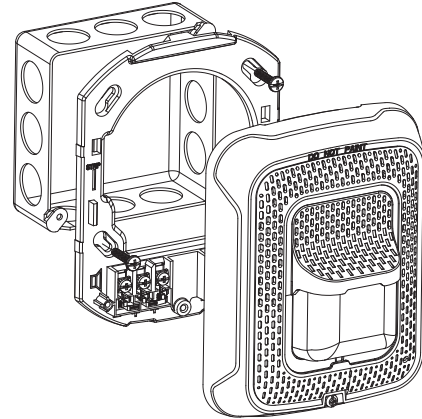

A0522-01

FIGURE 9. CEILING SPEAKER/STROBE

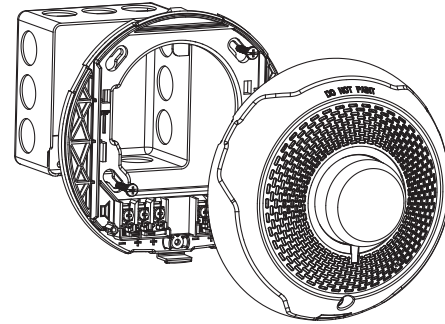

A0521-02

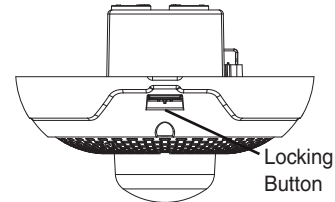

A0575-00

TAMPER SCREW

For tamper resistance, the standard captive screw may be replaced with a Torx screw (sold separately).

1. To remove the captive screw, back out the screw and apply pressure to the back of the screw until it disengages from the housing. Replace with Torx screw. (See Figure 10.)

FIGURE 10. TAMPER SCREW

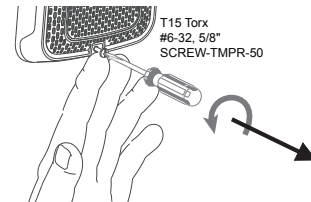

A0502-01

INSTALLING A SURFACE MOUNT BACK BOX

1. The surface mount back box may be secured directly to the wall or ceiling. Use of grounding bracket with ground screw is optional. (See Figures 11 and 12.)
2. The wall mount box must be mounted with the up arrow pointing up. (See Figure 13.)

NOTE: Ceiling Surface Mount Back Box SBBCR/CWL is a common back box for ceiling horn strobes, strobes and ceiling speakers and speaker strobes. Use

the top mounting holes for ceiling speaker and speaker strobe products. (See Figure 14.)

3. Threaded knockout holes are provided for the sides of the box for conduit adapter. Knockout holes in the back of the box can be used for rear entry.

4. To remove the conduit knockout, place the blade of a flat-head screwdriver along the outer edge and work your way around the knockout as you strike the screwdriver. (See Figure 15A.)

NOTE: Use caution not to strike the knockout near the top edge of the surface mount back box.

5. V500 and V700 raceway knockouts are also provided. Use V500 for low profile applications and V700 for high profile applications.

6. To remove the knockout, turn pliers up. (See Figure 15B.)

Ceiling Models only: To remove product from the mounting plate, press the locking button after loosening the captive mounting screw.

FIGURE 11. SURFACE MOUNTING ON WALL

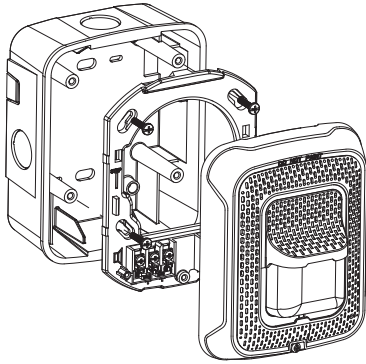

A0523-01

FIGURE 12. SURFACE MOUNTING ON CEILING

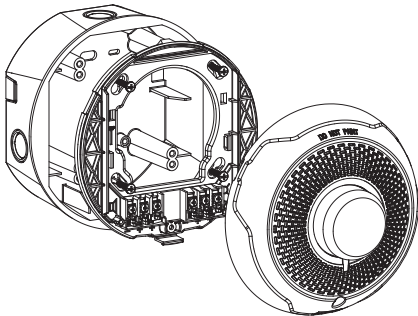

A0520-02

FIGURE 13. SURFACE MOUNT BACK BOX UP ARROW

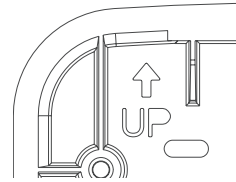

A0481-00

FIGURE 14. CEILING INSTALLATION WITH A SURFACE MOUNT BACK BOX: KEY HOLE PATTERN

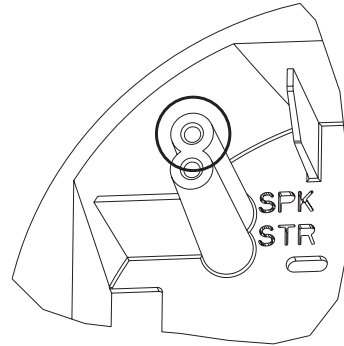

A0505-00

FIGURE 15A AND 15B. KNOCKOUT AND WIRE MOLD REMOVAL FOR SURFACE MOUNT BACK BOX

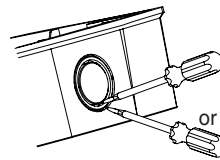

A0465-01

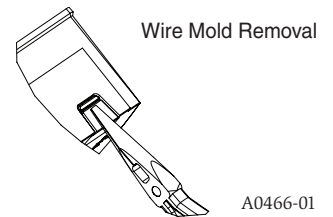

A0466-01

NOTE: Use caution not to strike the knockout near the top edge of the wall version of the surface mount back box.

FCC STATEMENT

These speakers have been tested and found to comply with the limits for a Class B digital device, pursuant to part 15 of the FCC Rules. These limits are designed to provide reasonable protection against harmful interference when the equipment is operated in a commercial environment. This equipment generates, uses, and can radiate radio fre-

quency energy and, if not installed and used in accordance with the instruction manual, may cause harmful interference to radio communications. Operation of this equipment in a residential area is likely to cause harmful interference in which case the user will be required to correct the interference at his own expense.



THE LIMITATIONS OF SPEAKERS

Always make sure that the individual speakers are tested after installation per NFPA regulations. The speakers may not be heard. The loudness of the speaker meets (or exceeds) current Underwriters Laboratories' standards. However, the speaker may not alert a sound sleeper or one who has recently used drugs or has been drinking alcoholic beverages. The speaker may not be

heard if it is placed on a different floor from the person in hazard or if placed too far away to be heard over the ambient noise such as traffic, air conditioners, machinery or music appliances that may prevent alert persons from hearing the alarm. The speaker may not be heard by persons who are hearing impaired.