



TRIGA Life Safety Systems, LLC
 7600 Olde Eight Rd, Hudson, Ohio, 44236-1057
 Tel: +1 330-577-5199, Email: info@trigaglobal.com

TR-NIC Network Interface Card Product Installation Document

PN LS10172-003TR-E:A 05/112/21 ECN: 151608

1 Description

The TR-NIC Network Interface Card is used when you want to network a group of Triga Series, Fire Alarm Control Panels (FACPs). You must use the TR-NIC to link the panels together.

NOTE: The installation and wiring of this device shall be performed in accordance with the NFPA 72 and the local ordinances.

1.1 Compatibility

The TR-NIC is compatible with the following Triga Series, Fire Alarm Control Panel (FACP).

- TR-2100
- TR-2100ECS

For information on the programming, addressing, networking/common communication links, refer to the following FACP Installation Manuals:

Document	Document Part Number
TRI-2100/ECS Manual	LS10143-003TR-E
TR-RPS1 Manual	LS10259-002TR-E

NOTE: The TR-NIC provides a common communications link. These panels cannot be linked together for peer-to-peer networking.

1.2 Specifications

The specifications are as follows:

- Standby Current: 21mA
- Alarm Current: 21mA
- Operating Voltage: 24VDC
- Operating Temperature: 32°F to 120°F (0°C to 49°C)

2 Layout and Mounting

The TR-NIC can be mounted within the FACP cabinet or mounted in the TR-NIC-KIT accessory cabinet. See Figure 1. The Accessory cabinets include the TR-NIC, a small cabinet with a door, a cable, and the mounting hardware.

The TR-NIC-KIT Accessory Kit is available if you want to install the TR-NIC outside of the FACP cabinet. For additional information, refer to the TR-NIC-KIT Installation Instructions, P/N LS10171-003TR-E.

Figure 1 shows the TR-NIC.

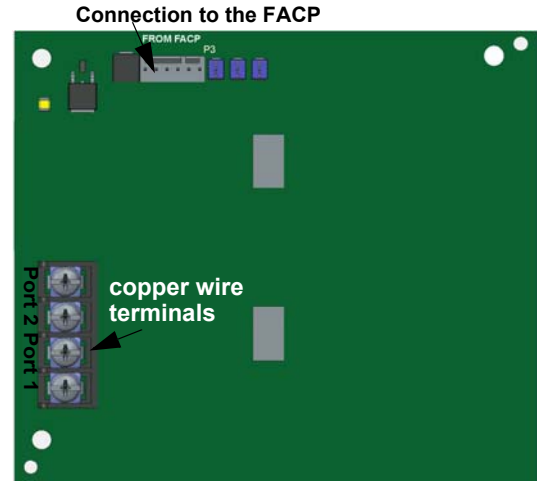

Figure 1 TR-NIC View

3 Wiring

3.1 TR-NIC to the FACP Installation

To properly connect the TR-NIC to the FACP port, use the supplied 6-pin cable, P/N: 130372-L8 and refer to the following steps.

1. Place the TR-NIC on one of the SLC expander standoff sets.
2. Use the 6-pin cable to connect one end of the cable to the FACP pin connector labeled, “Data Network” and connect the other end of the cable to the TR-NIC Card P3-connector. Refer to Figure 2.

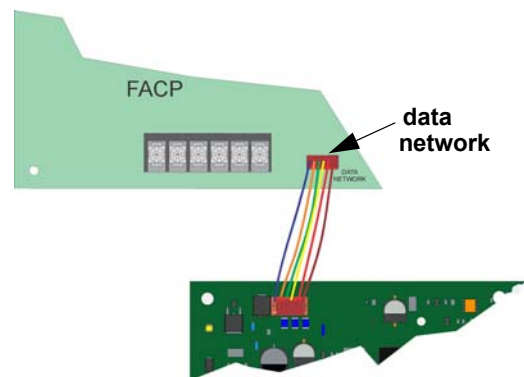

Figure 2 TR-NIC to Panel Connection

3.2 TR-NIC Remote Location Installation

To mount the TR-NIC in a remote location, refer to Step 1 and Step 2 in Section 3.1.

1. If you use the 6-pin cable, run the cable from the TR-NIC to the FACP. It must be run in conduit.
2. Refer to Figure 3 when using the TR-NIC-KIT or TR-5815RMK.

Figure 3 shows the TR-NIC installation to the TR-NIK-KIT.

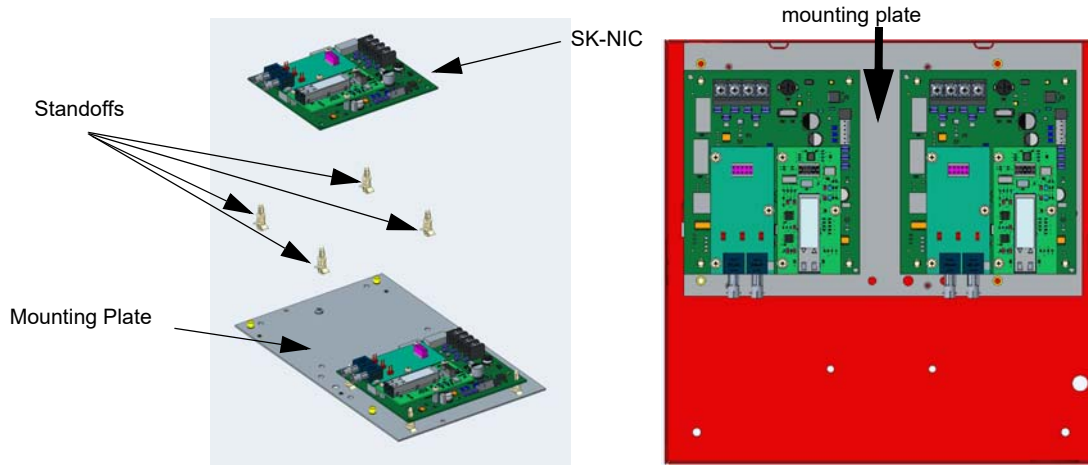

Figure 3 Mounting the TR-NIC in the TR-NIC-KIT or 5815RMK



NOTE: For more information, see the FACP Installation Manual.

3.3 Fiber Loop Modules

Figure 4 illustrates the TR-NIC fiber loop modules or wire terminals.

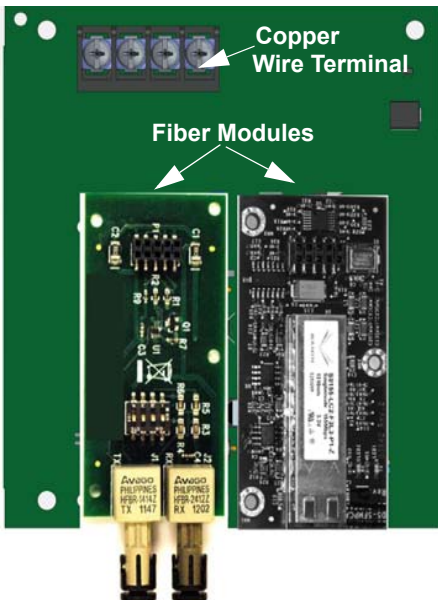

Figure 4 TR-NIC Fiber Loop Modules or Wire Terminals

The TR-NIC connects to other networked units using unshielded, twisted-pair wiring or fiber-optic cable. The TR-FML (Fiber-Optic Multi-Mode) and TR-FSL (Fiber-Optic Single-Mode) modules are plug-in fiber loop modules. The two types of fiber-optic modules are used as one channel to transmit or receive communications with the TR-NIC, ARCNET Communication Circuit.

The following describe the two types of fiber-optic modules:

- The TR-FML is a fiber module that allows the multi-mode fiber to network between nodes.
- The TR-FSL is a fiber module that allows the single-mode fiber to network between nodes.



NOTE: For more information on the TR-FML and TR-FSL, refer to the TR-FML/TR-FSL Installation Instructions, P/N LS10178-003TR-E.