

## TRW-RELAY Wireless Relay Module

### SPECIFICATIONS

Maximum Operating Voltage:	3.3 VDC
Maximum Current Draw:	5.0 mA (LED on)
Average Operating Current:	210uA
Maximum Transmit RF Power:	17dBm
Radio Frequency Range:	902-928 MHz
Temperature Range:	32°F to 120°F (0°C to 49°C)
Humidity:	10% to 93% Non-condensing
Battery Type:	4 Panasonic CR123A or 4 Duracell DL123A
Battery Life:	2 year minimum
Battery Replacement:	Upon TROUBLE BATTERY LOW display and/or during annual maintenance
Dimensions:	4¼" H x 4¼" W x 1½" D (11.4 cm H x 11.4 cm W x 3.81 cm)
Accessories:	TR-SMB500-WH Electrical Box (preferred mounting option)

### RELAY CONTACT RATINGS

CURRENT RATING	MAXIMUM VOLTAGE	LOAD DESCRIPTION	APPLICATION
2 A	25 VAC	PF = 0.35	Non-coded
3 A	30 VDC	Resistive	Non-coded
2 A	30 VDC	Resistive	Coded
0.46 A	30 VDC	(L/R = 20ms)	Non-coded
0.7 A	70.7 VAC	PF = 0.35	Non-coded
0.9 A	125 VDC	Resistive	Non-coded
0.5 A	125 VAC	PF = 0.75	Non-coded
0.3 A	125 VAC	PF = 0.35	Non-coded

### BEFORE INSTALLING

This information is included as a quick reference installation guide. Refer to the control panel installation manual and the SWIFT® Wireless Gateway Manual for detailed system information. If the modules will be installed in an existing operational system, inform the operator and local authority that the system will be temporarily out of service. Disconnect power to the control panel before installing the modules.

NOTICE: This manual should be left with the owner/user of this equipment.

### GENERAL DESCRIPTION

The TRW-RELAY Relay Module is intended for use with a wireless gateway or wireless fire alarm control panel (FACP). It allows a compatible control panel to switch discrete contacts by code command. The relay contains one isolated set of Form-C contacts, which operate as a SPDT switch and are rated in accordance with the table in this manual. A single relay module may be used to activate only one output device. Two relay modules must be used in parallel to activate multiple devices such as a NAC expander. Circuit connections to the relay are not supervised by the module. The device communicates through a robust, bi-directional mesh network to the gateway and/or FACP. Rotary decade switches are provided for setting the module's address. The module has a panel controlled LED indicator. (See Figure 1.)

**FIGURE 1. CONTROLS AND INDICATORS**

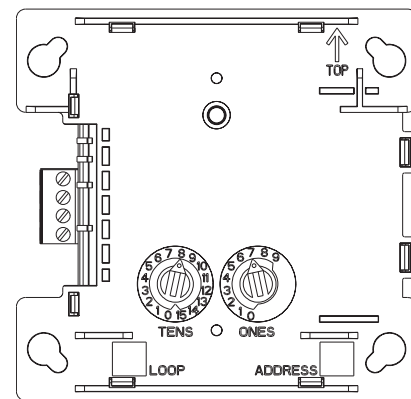

C1095B-00

### FACEPLATE

The faceplate includes a magnet for activation and tamper resistance. (See Figure 2.) The faceplate magnet activates communication to the panel, therefore, the faceplate must be installed for the module to work properly. The magnet also activates a supervisory tamper fault at the panel if the nameplate is removed. Do NOT remove this magnet. The faceplate for a wireless module CANNOT be replaced with the faceplate of a standard wired module.

**FIGURE 2. FACEPLATE INTERIOR**

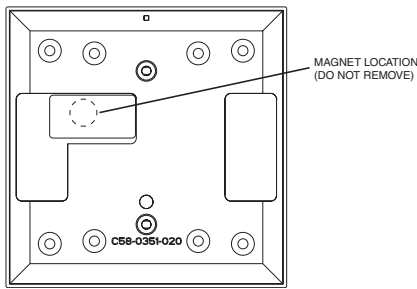

C1098-00

**COMPATIBILITY REQUIREMENTS**

To ensure proper operation, this module shall be connected to a compatible Triga system control panel (list available from Triga).

**BATTERY REPLACEMENT**

Low battery levels on the wireless devices are displayed as a trouble in the FACP. Therefore when the message “TROUBLE BATTERY LOW” is displayed, replace the battery in the device. This message is an indication that approximately one week of battery life remains.

To replace the batteries in a wireless device use the following steps:

1. Have 4 CR123A (or DL123A) batteries available
2. Remove the faceplate from the module.
3. Open the battery compartment refer to Figure 3.
4. Remove the used batteries and replace with new batteries. The battery compartment is designed such that the batteries can only align in the appropriate direction. Do not force the batteries into the openings.
5. Replace the battery compartment cover.
6. Replace the faceplate.

**FIGURE 3. BATTERY COMPARTMENT**

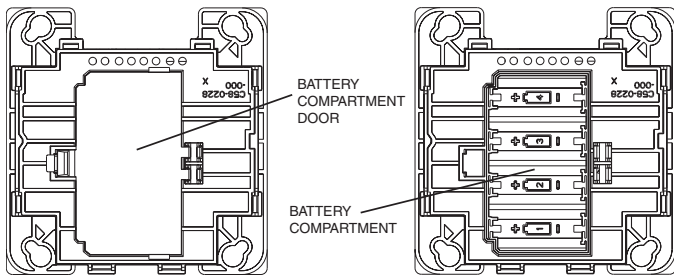

C2002-01

**SPACING**

Wireless technologies can exhibit communication disruption if devices are spaced too close together. To avoid this form of disruption, SWIFT devices should not be placed closer than 2 feet (60 cm) apart without an intervening structure.

**MOUNTING**

The TRW-RELAY mounts directly to a TR-SMB500-WH electrical box. (See Figure 4.) To avoid interference with the wireless network metal electrical boxes are NOT recommended. Non-metal surface mounted electrical boxes (TR-SMB500-WH) are available. If not using a TR-SMB500-WH, the minimum mounting opening dimensions for the TRW-RELAY are 4" X 3 3/4" x 1 1/2" deep (10.16 cm x 9.52 cm x 3.81 cm).

NOTE: Do not attach the module to temporary structures in such a way that the placement could be altered.

**WIRING**

NOTE: All wiring must conform to applicable local codes, ordinances, and regulations. For applications interfacing with Emergency Control Functions, field wiring shall be limited to 3' (0.9 m) or 20' (6.1 m) in non-metallic conduit.

1. Install module wiring in accordance with the job drawings and appropriate wiring diagrams.
2. Set the address on the module per job drawings.
3. Secure module to electrical box (supplied by installer), as shown in Figure 4.

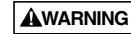

All relay switch contacts are shipped in the standby state (open) state, but may have transferred to the activated (closed) state during shipping. To ensure that the switch contacts are in their correct state, modules must be made to communicate with the panel before connecting circuits controlled by the module. When interfacing with an emergency control function, that function must respond in 1 second or less.

**FIGURE 4. MODULE MOUNTING**

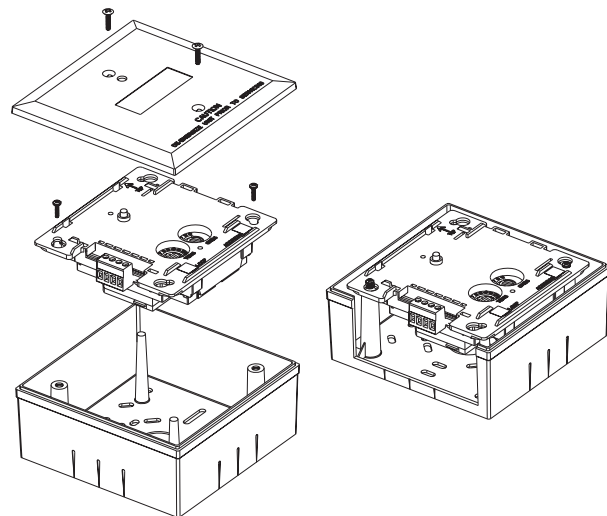

C1096B-01

**FIGURE 5. TYPICAL WIRING CONFIGURATION**

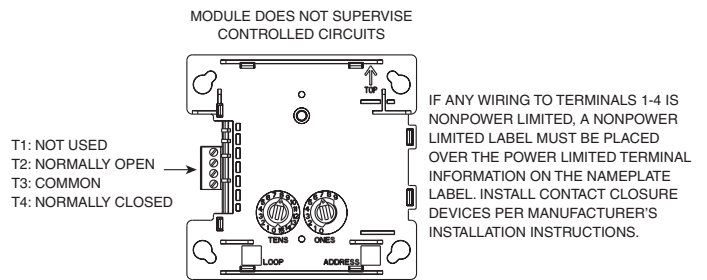

NOTE: IN APPLICATIONS INTERFACING WITH EMERGENCY CONTROL FUNCTIONS, FIELD WIRING SHALL BE LIMITED TO 3 FEET OR 20 FEET IN NON-METALLIC CONDUIT.

C2019B-00

**LICENSING STATEMENT**

Use of these products in combination with non-Honeywell products in a wireless mesh network, or to access, monitor or control devices in a wireless mesh network via the internet or another external wide area network, may require a separate license from Sipco,

LLC. For more information, contact Sipco, LLC or Ipco, LLC at 8215 Roswell Rd., Building 900, Suite 950, Atlanta, GA 303350, or at [www.sipcollc.com](http://www.sipcollc.com) or [www.intusiq.com](http://www.intusiq.com).

**FCC STATEMENT**

This device complies with part 15 of the FCC Rules. Operation is subject to the following two conditions:

1. This device may not cause harmful interference, and
2. This device must accept any interference received, including interference that may cause undesired operation.

WARNING: Do not make changes to the equipment. Changes or modifications not expressly approved by the manufacturer could void the user's authority to operate the equipment.

Triga™ is a trademark of TRIGA Life Safety Systems, LLC. SWIFT® is a registered trademark of Honeywell International, Inc.