

TR-RELAY-6

Six Relay Control Module

TRIGA Life Safety Systems, LLC
 7600 Olde Eight Rd.
 Hudson, Ohio 4426-1057
 Tel: +1 330-577-5199. Email: info@trigaglobal.com

SPECIFICATIONS

Normal Operating Voltage: 15-32 VDC Stand-By Current:1.90 mA @ 24V
 Alarm Current: 32 mA (assumes all six relays have been switched once and all six LEDs solid on)
 Temperature Range: 32°F to 120°F (0°C to 49°C)
 Humidity: 10 to 93% Non-condensing
 Dimensions: 6.8" H × 5.8" W × 1.0" D (17.3 cm x 14.7 cm x 2.5 cm)
 Accessories: TR-ACB cabinet and chassis
 Wire Gauge: 12-18 AWG
 Relay Current: 30 mA/Relay Pulse (15.6 mS pulse duration) pulse under panel control

RELAY CONTACT RATINGS

CURRENT RATING	MAXIMUM VOLTAGE	LOAD DESCRIPTION	APPLICATION
2 A	25 VAC	PF = 0.35	Non-coded
3 A	30 VDC	Resistive	Non-coded
2 A	30 VDC	Resistive	Coded
0.46 A	30 VDC	(L/R = 20ms)	Non-coded
0.7 A	70.7 VAC	PF = 0.35	Non-coded
0.9 A	125 VDC	Resistive	Non-coded
0.5 A	125 VAC	PF = 0.75	Non-coded
0.3 A	125 VAC	PF = 0.35	Non-coded

BEFORE INSTALLING

If the modules will be installed in an existing operational system, inform the operator and local authority that the system will be temporarily out of service. Disconnect the power to the control panel before installing the modules. This system contains static sensitive components. Always ground yourself with a proper wrist strap before handling any circuits so that static charges are removed from the body. The housing cabinet should be metallic and suitably grounded.

NOTICE: This manual should be left with the owner/user of this equipment.

GENERAL DESCRIPTION

The TR-RELAY-6 Six Relay Control Module is intended for use in an intelligent alarm system. Each module is intended for Form-C switching applications, which do not require wiring supervision for the load circuit. A single isolated set of dry relay contacts is provided for each module, which is capable of being wired for either normally open or normally closed for each operation. Each module has its own address. A pair of rotary code switches is used to set the address of the first module from 01 to 94 (or 01 to 154 for panels that support 159 addresses). The remaining modules are automatically assigned to the next five higher addresses. Provisions are included for disabling a maximum of three unused modules to release the addresses to be used elsewhere. Each TR-RELAY-6 module also has panel controlled green LED indicators. The panel can cause the LEDs to blink, latch on, or latch off.

CONTENTS INCLUDE:

- (6) 1 × 3 Terminal Blocks
- (1) 1 × 4 Terminal Blocks
- (2) 1¼" (32mm) Stand offs
- (4) Machine Screws
- (2) Nuts
- (1) Shunt (NOTE: For the disable position, not more than one shunt shall be installed at the same time)

COMPATIBILITY REQUIREMENTS

To ensure proper operation, this module shall be connected to a compatible Triga series system control panel.



All relay switch contacts are shipped in the standby state (open) state, but may have transferred to the activated (closed) state during shipping. To ensure that the switch contacts are in their correct state, modules must be made to communicate with the panel before connecting circuits controlled by the module.

COMPONENTS

The following is a description of the TR-RELAY-6 mounting framework:

- One or two TR-RELAY-6 modules can be installed in a TR-ACB cabinet

The TR-ACB cabinet has a built-in chassis that will accommodate one or two TR-RELAY-6 modules.

FIGURE 1. TR-ACB CABINET

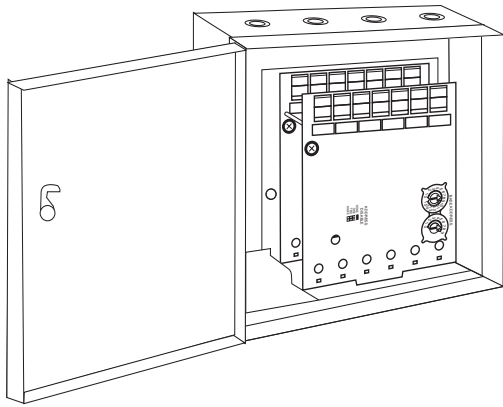

C0234-05

The front TR-RELAY-6 module positions of each chassis are offset below the rear TR-RELAY-6 module positions so that all of the status indicators are visible. For cabinet dimensions refer to TR-ACB instruction manual.

INSTALLATION STEPS

1. Cabinet Mounting

In a clean, dry area, mount the backbox using the four holes provided in the back surface of the cabinet.

FIGURE 2. TYPICAL MOUNTING HOLE LOCATIONS

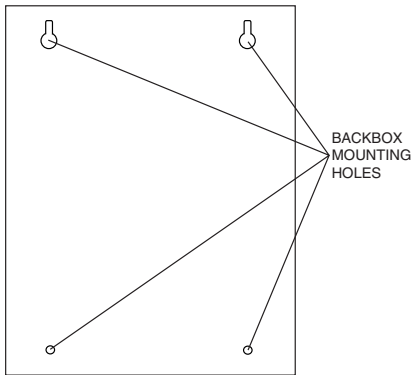

C0235-00

2. Module Installation

There are two methods for installing a module in the rear position of a chassis. Method one is for installation of a rear module only, when no module will be installed in front of it. Refer to Figure 3 for instructions. Method two is for installation of a rear module when another module will be installed in the chassis position in front of it. Refer to Figures 4a and 4b for method two. All necessary screws and standoffs are supplied with the modules.

FIGURE 3. INSTALLATION OF REAR MODULE ONLY, METHOD ONE

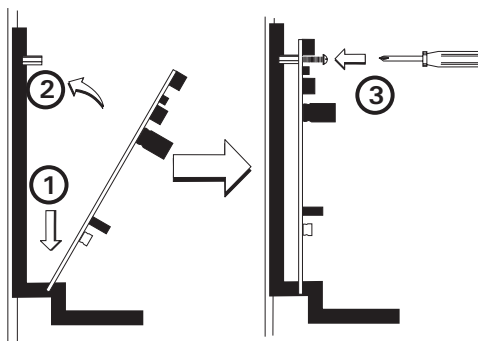

C0249-00

Step 1: Insert the bottom of the TR-RELAY-6 module down into a rear slot on the chassis.

Step 2: Carefully swing the upper edge of the board back towards the back of the chassis until it touches the two standoffs.

Step 3: Align two 4-40 screws with the two standoffs and tighten.

Step 4: Address and wire the modules according to the instructions in this manual.

The steps in Figures 4a and 4b describe and illustrate module installation when the rear chassis position and the position in front of it will be filled. Front position installation is possible only if the rear position is filled with a module.

FIGURE 4A. INSTALLATION OF TR-RELAY-6 MODULE IN A REAR CHASSIS POSITION, METHOD TWO

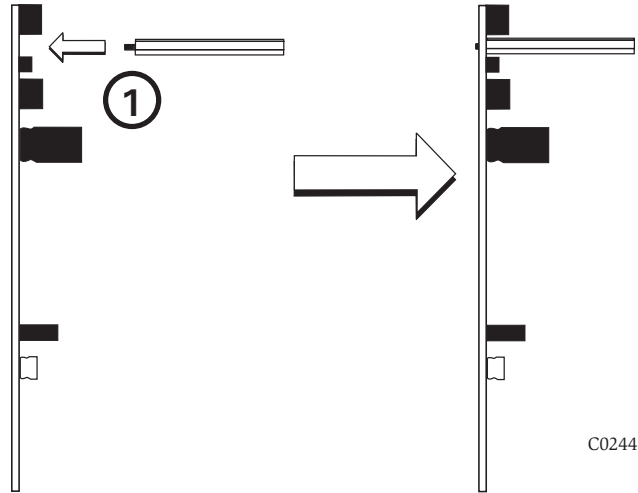

C0244-00

Step 1: Insert the bottom edge of the TR-RELAY-6 module down into a rear slot of the chassis.

Step 2: Carefully swing the bottom edge of the board towards the back of the board until it touches the short standoff attached to the chassis.

Step 3: Align the long standoff with the short standoff and tighten.

FIGURE 4B. INSTALLATION OF TR-RELAY-6 MODULE IN FRONT CHASSIS POSITION

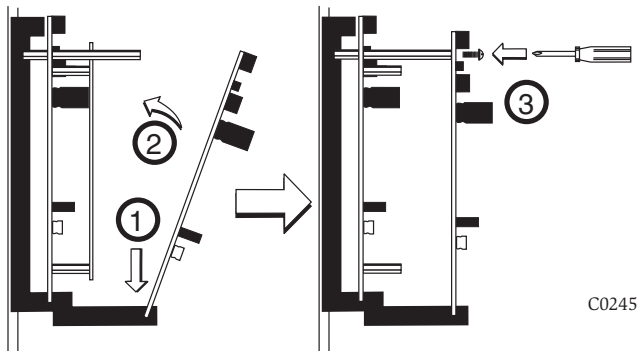

C0245-00

Step 1: Insert the bottom edge of the TR-RELAY-6 module down into a front slot of the chassis.

Step 2: Carefully swing the upper edge of the board towards the back of the chassis until it touches the 1/4" (31.75mm) standoffs installed on the rear module.

Step 3: Align two 4-40 screws with the two standoffs and tighten.

Step 4: Address and wire the modules according to the instructions in this manual.

WIRING

NOTE: All wiring must conform to applicable local codes, ordinances, and regulations.

1. Install module wiring in accordance with the job drawings and appropriate wiring diagrams.
2. Make electrical connections by stripping approximately ¼" (6.4 mm) of insulation from the end of the wire sliding the bare end of the wire under the clamping plate, and tightening the clamping plate screw.
3. Set the address on the modules per the job drawing. Use the rotary code switches to set the address of the first module between 01 and 94 (or 01 and 154 for panels that support 159 addresses). The remaining modules are automatically assigned to the next five higher addresses. For example, if the base address switch is set to 28, the next five modules will be addressed to 29, 30, 31, 32, and 33. DO NOT set the lowest address above 94 (or 154 for panels that support 159 addresses), as the other modules will be assigned to nonexistent addresses.
4. A shunt is provided to disable a maximum of three unused modules. Modules are disabled from the highest address and work downward. If two modules are disabled, the lowest four addresses will be functional, while the highest two will be disabled. For example, if the shunt for Address Disable is placed on "two" and the base address switch is set to 28, the modules will be assigned to 28, 29, 30 and 31.

NOTE: All references to power limited represent "Power Limited (Class 2)".

NOTE: The TR-RELAY-6 must have power cycled for shunt changes to take effect.

NOTE: Power must not be applied to the unit when changing functionality of the shunts

NOTES:

- The relay contacts on the TR-RELAY-6 may be connected to either a power-limited or non power-limited source, this wiring must remain separated by at least ¼" (6.4 mm) from all power-limited wiring.
- Power-limited circuits must employ type FPL, FPLR, or FPLP cable as required by Article 760 of the NEC.
- For easier wiring, assign all power-limited wiring to one side rather than alternating with non power-limited.

PROGRAMMING

The modules are programmed as modules in each system according to the programming instructions in the appropriate FACP manual.

FIGURE 5. WIRING AND PROGRAMMING THE TR-RELAY-6 MODULE

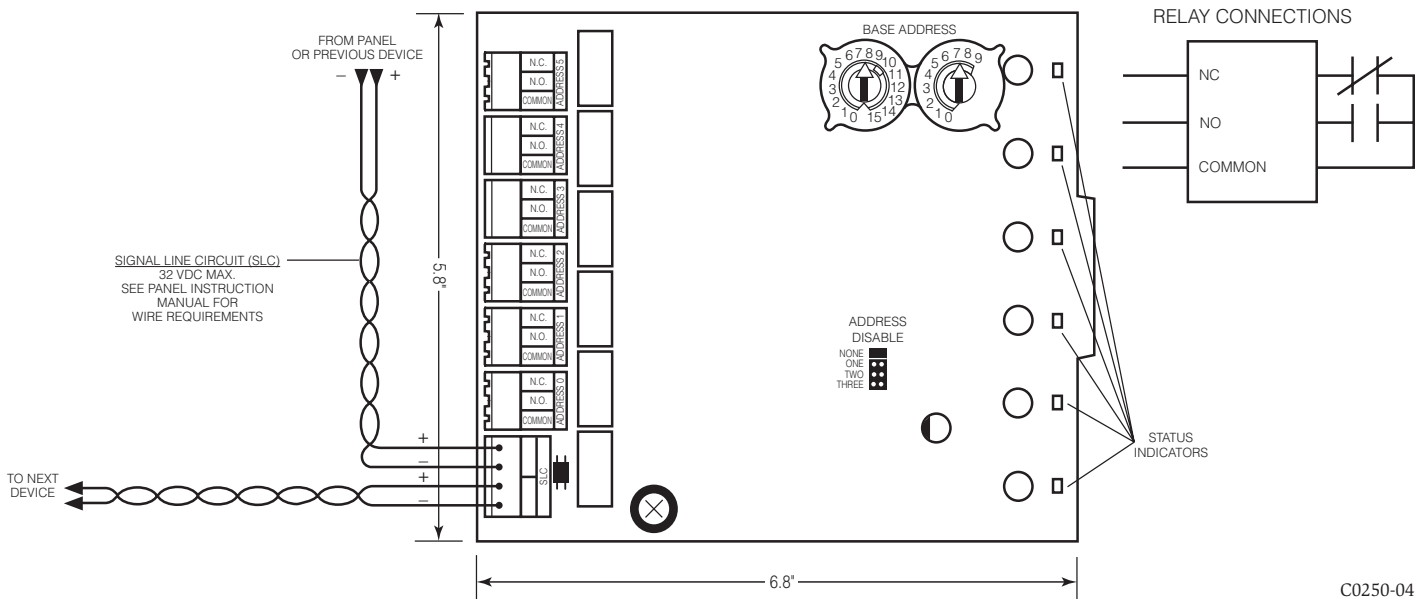

C0250-04

FCC STATEMENT

This device complies with part 15 of the FCC Rules. Operation is subject to the following two conditions: (1) This device may not cause harmful interference, and (2) this device must accept any interference received, including interference that may cause undesired operation.

NOTE: This equipment has been tested and found to comply with the limits for a Class B digital device, pursuant to Part 15 of the FCC Rules. These limits are designed to provide reasonable protection against harmful interference in a residential installation. This equipment generates, uses and can radiate radio frequency energy and, if not installed and used in accordance with the instructions, may cause harmful interference to radio communications. However, there is no guarantee that interference will not occur in a particular installation. If this equipment does cause harmful interference to radio or television reception, which can be determined by turning the equipment off and on, the user is encouraged to try to correct the interference by one or more of the following measures:

- Reorient or relocate the receiving antenna.
- Increase the separation between the equipment and receiver.
- Connect the equipment into an outlet on a circuit different from that to which the receiver is connected.
- Consult the dealer or an experienced radio/TV technician for help.

DEVICE AND SYSTEM SECURITY

Before installing this product ensure that the tamper seal on the packaging is present and unbroken and the product has not been tampered with since leaving the factory. Do not install this product if there are any indications of tampering. If there are any signs of tampering the product should be returned to the point of purchase.

It is the responsibility of the system owner to ensure that all system components, i.e. devices, panels, wiring etc., are adequately protected to avoid tampering of the system that could result in information disclosure, spoofing, and integrity violation.