

TR-CONTROL-6

Six Circuit Supervised Control Module

TRIGA Life Safety Systems, LLC
 7600 Olde Eight Rd.
 Hudson, Ohio 4426-1057
 Tel: +1 330-577-5199. Email: info@trigaglobal.com

SPECIFICATIONS

Normal Operating Voltage:	15-32 VDC
Stand-By Current:	2.65 mA @ 24V
Alarm Current:	35 mA (assumes all six relays have been switched and all six LEDs solid on)
Temperature Range:	32°F to 120°F (0°C to 49°C)
Humidity:	10 to 93% Non-condensing
Dimensions:	6.8" H x 5.8" W x 1.25" D (172.7mm x 147.3 mm x 31.75mm)
Accessories:	TR-ACB Cabinet and chassis
Wire Gauge:	12-18 AWG
Max. NAC Circuit Line Loss:	4 VDC
Max. NAC Current Ratings:	For class B wiring systems, 3A For class A wiring systems, 2A

RELAY CONTACT RATINGS

CURRENT RATING	MAXIMUM VOLTAGE	LOAD DESCRIPTION	APPLICATION
2 A	25 VAC	PF = 0.35	Non-coded
3 A	30 VDC	Resistive	Non-coded
2 A	30 VDC	Resistive	Coded
0.46 A	30 VDC	(L/R = 20ms)	Non-coded
0.7 A	70.7 VAC	PF = 0.35	Non-coded
0.9 A	125 VDC	Resistive	Non-coded
0.5 A	125 VAC	PF = 0.75	Non-coded
0.3 A	125 VAC	PF = 0.35	Non-coded

BEFORE INSTALLING

If the modules will be installed in an existing operational system, inform the operator and local authority that the system will be temporarily out of service. Disconnect the power to the control panel before installing the modules. This system contains static sensitive components. Always ground yourself with a proper wrist strap before handling any circuits so that static charges are removed from the body. The housing cabinet should be metallic and suitably grounded.

NOTICE: This manual should be left with the owner/user of this equipment.

GENERAL DESCRIPTION

The TR-CONTROL-6 Six Circuit Supervised Control Module is intended for use in an intelligent alarm system. Each module is intended for switching applications involving AC, or DC which require wiring supervision. A common SLC input is used for all modules. Each module has its own address. A pair of rotary code switches is used to set the address of the first module from 01 to 94 (or 01 to 154 for panels that support 159 addresses). The remaining modules are automatically assigned to the next five higher addresses. Provisions are included for disabling a maximum of three unused modules to release the addresses to be used elsewhere. Each module also has panel controlled green LED indicators. The panel can cause the LEDs to blink, latch on, or latch off. In order to synchronize strobes, horn/strobes, and speaker/strobes, a SYNC-1 accessory card (sold separately) must be used with the TR-CONTROL-6. See the SYNC-1 installation manual for details on how to install.

Each module has terminals for connection to an external supply circuit for powering devices on its NAC. Each supply must be power limited and its voltage/current limits must be at or below those specified. There is a short circuit protection monitor for each module. This is provided to protect the external power supply against short circuit conditions on the NAC.

SHIPPED ON BOARD:

- (1) Small shunt in A/B select position (Shipped in Class B position, remove shunt for Class A)
- (6) Large shunts on Enable Power Supply Monitors
- (6) Large shunts on Disable Short Circuit Protection
- (3) Large shunts on Sync Generator

INCLUDED:

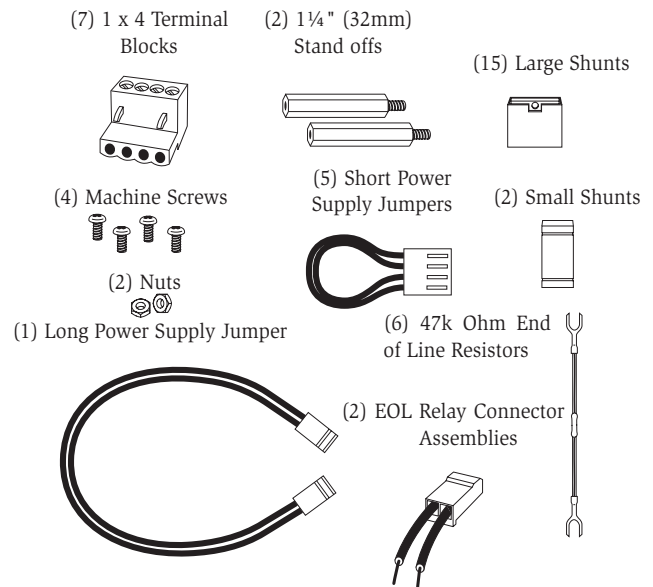

TABLE 1. SHORT CIRCUIT PROTECTION - UL 864 9TH EDITION REQUIREMENTS

NOTICE TO USERS, INSTALLERS, AUTHORITIES HAVING JURISDICTION, AND OTHER INVOLVED PARTIES			
This product incorporates field-programmable software. In order for the product to comply with requirements in the Standard for Control Units and Accessories for Fire Alarm Systems, UL 864, certain programming features or options must be limited to specific values or not used at all as indicated below.			
Program Feature or Option	Permitted in UL 864 (Y/N)	Possible Settings	Settings Permitted in UL 864
Disabling short circuit protection when a single power supply is shared by multiple NACs	No	Enable or Disable short circuit protection	Enable short circuit protection when a single power supply is shared by multiple NACs. Short circuit protection can be disabled only when a power supply is not shared by multiple NACs.

COMPATIBILITY REQUIREMENTS

To ensure proper operation, this module shall be connected to a compatible Triga system control panel.

COMPONENTS

The following is a description of the TR-CONTROL-6 mounting framework:

- One or two TR-CONTROL-6 modules can be installed in a TR-ACB cabinet.

The TR-ACB cabinet has a built-in chassis that will accommodate one or two TR-CONTROL-6 modules.

FIGURE 1. TR-ACB CABINET

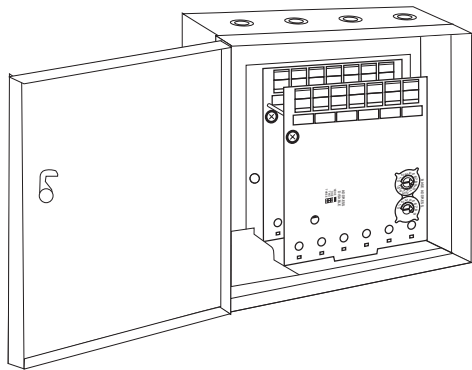

C0234-03

The front TR-CONTROL-6 module positions of each chassis are offset below the rear TR-CONTROL-6 module positions so that all of the status indicators are visible. For cabinet dimensions refer to the TR-ACB instruction manual.

INSTALLATION STEPS

1. Cabinet Mounting

In a clean, dry area, mount the backbox using the four holes provided in the back surface of the cabinet. (See Figure 3.)

FIGURE 2. TYPICAL MOUNTING HOLE LOCATIONS

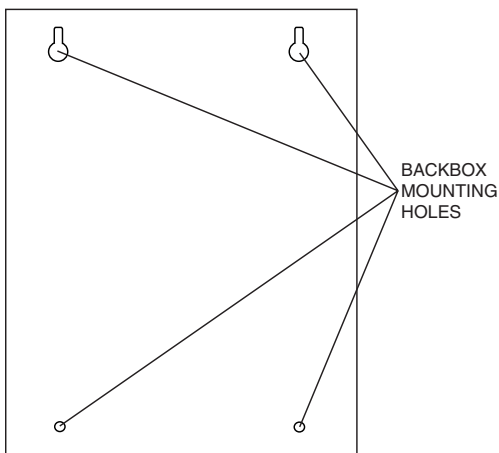

C0235-00

2. Module Installation

There are two methods for installing a module in the rear position of a chassis. Method one is for installation of a rear module only, when no module will be installed in front of it. Refer to Figure 3 for instructions. Method two is for installation of a rear module when another module will be installed in the chassis position in front of it. Refer to Figures 4a and 4b for method two. All necessary screws and standoffs are supplied with the modules.

FIGURE 3. INSTALLATION OF REAR MODULE ONLY, METHOD ONE

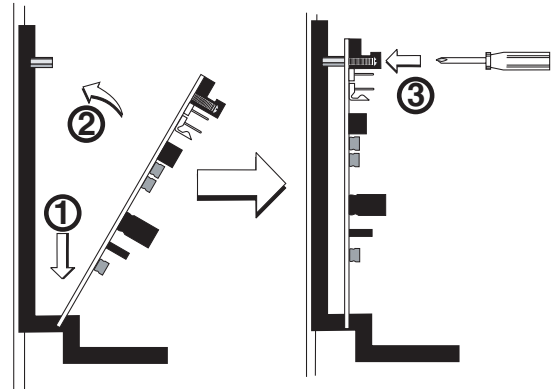

C0237-00

- Step 1: Insert the bottom of the TR-CONTROL-6 module down into a rear slot on the chassis.
- Step 2: Carefully swing the upper edge of the board back towards the back of the chassis until it touches the two standoffs.
- Step 3: Align two 4-40 screws with the two standoffs and tighten.
- Step 4: Address and wire the modules according to the instructions in this manual.

The steps in Figures 4a and 4b describe and illustrate module installation when the rear chassis position and the position in front of it will be filled. Front position installation is possible only if the rear position is filled with a module.

FIGURE 4A. INSTALLATION OF TR-CONTROL-6 MODULE IN A REAR CHASSIS POSITION, METHOD TWO

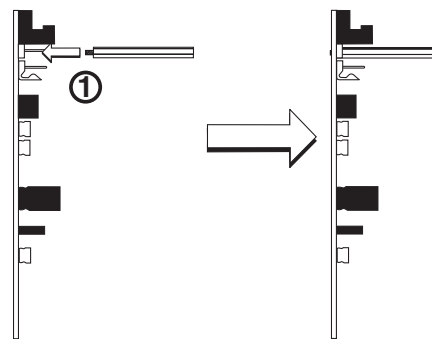

C0225-00

- Step 1: Insert the bottom edge of the TR-CONTROL-6 module down into a rear slot of the chassis.
- Step 2: Carefully swing the upper edge of the board towards the back of the chassis until it touches the short standoff attached to the chassis.
- Step 3: Align the long standoff with the short standoff and tighten.

FIGURE 4B. INSTALLATION OF TR-CONTROL-6 MODULE IN FRONT CHASSIS POSITION

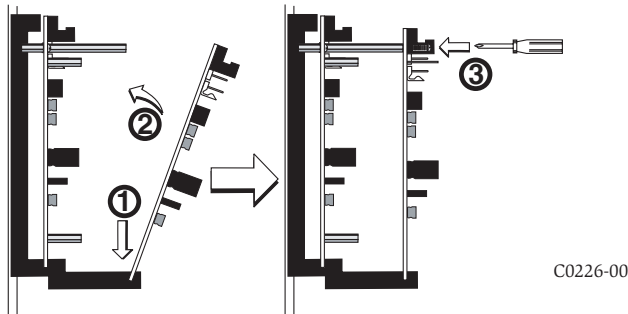

- Step 1: Insert the bottom edge of the TR-CONTROL-6 module down into a front slot of the chassis.
- Step 2: Carefully swing the upper edge of the board towards the back of the chassis until it touches the 1 1/4" (31.75mm) standoffs installed on the rear module.
- Step 3: Align two 4-40 screws with the two standoffs and tighten.
- Step 4: Address and wire the modules according to the instructions in this manual.

WIRING

NOTE: All wiring must conform to applicable local codes, ordinances, and regulations.

1. Install module wiring in accordance with the job drawings and appropriate wiring diagrams.
2. All wiring to the TR-CONTROL-6 is done via terminal blocks. In order to properly make electrical connections strip approximately 1/4" (6.4 mm) of insulation from the end of wire, sliding the bare end of the wire under the clamping plate screw.
3. Set the address on the modules per the job drawing. Use the rotary code switches to set the address of the first module between 01 and 94 (or 01 and 154 for panels that support 159 addresses).

To select Class B operation, install the J1 Shunt. The remaining modules are automatically assigned to the next five higher addresses. For example, if the base address switch is set to 28, the next five modules will be addressed to 29, 30, 31, 32, and 33.

To select Class A operation, remove the J1 Shunt. A maximum of three Class A circuits are available. For example, if the base address switch is set to 28, 30 and 32 will be automatically assigned to the modules while 29, 31 and 33 are available to be used for other modules on the SLC. For Class A and B operation, DO NOT set the lowest address above 94(or 154 for panels that support up to 159 addresses), as the other modules will be assigned to nonexistent addresses.

4. A shunt is provided to disable a maximum of three unused modules. (See Figure 5.) Modules are disabled from the highest address and work downward. If two modules are disabled, the lowest four addresses will be functional, while the highest two will be disabled. For example, if the shunt for Address Disable is placed on "two" and the base address switch is set to 28, the modules will be assigned to 28, 29, 30 and 31, disabling the highest two positions.

NOTE: In Class A operation, placing the small shunt on "disable 3" will disable all three addresses. Placing the small shunt on "disable 2" will disable two out of the three addresses. For example, if the address switch is set to 28 and the small shunt is placed on "disable" 2, addresses 30 and 32 will be disabled while address 28 will be enabled. The TR-CONTROL-6 must have power cycled for shunt changes to take effect.

5. There is an active short circuit protection option for each address. The board is shipped with this option disabled for each address represented by six large shunts on the "Disable Short Circuit Protection" area. To enable short circuit protection for an address, remove the corresponding shunts on the "Disable Short Protection" area. When enabled, this option will isolate a short occurring on any active circuit allowing the remaining circuits to continue normal operation.

NOTE: All references to power limited represent "Power Limited (Class 2)".
 NOTE: Short circuit protection may only be enabled if power supply monitoring is enabled.
 NOTE: Place unused shunts on single pin to store on board for future use.
 NOTE: Power must not be applied to the unit when changing functionality of the shunts.
 NOTE: Whether in Class B or Class A wiring, power supply monitoring and short circuit protection must be enabled on the NAC circuits that are sharing a power supply.
 NOTE: Short circuit protection can only be disabled if a power supply is not being shared by multiple NACs.

FIGURE 5.

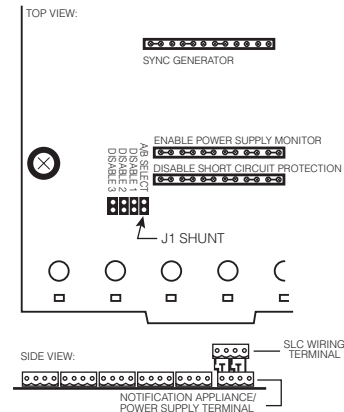

C0174-00

NOTE: SLC wiring is the top terminal block, notification appliance/power supply is the bottom.

WIRING NOTES

- Power-limited circuits must employ type FPL, FPLR, or FPLP cable as required by Article 760 of the NEC.
- For easier wiring, assign all power-limited wiring to one side of the enclosure rather than alternating with non power-limited.

PROGRAMMING

The modules are programmed as devices in each system according to the programming instructions in the appropriate FACP manual.

NAC WIRING AND SUPERVISION

For Class B applications (figures 6 and 7 are typical): connect the positive terminal of the notification appliance(s) to the NAC+ terminal and the negative device terminal to the adjacent NAC- terminal. Connect one (for each NAC) of the supplied EOL resistors across the NAC+ and NAC- wires, at the ends farthest away from the NAC terminal of the TR-CONTROL-6.

For Class A applications (figures 8 and 9 are typical) wire the NACs per Table 2. The A/B select shunt must be removed prior to connecting the TR-CONTROL-6 to the SLC. The EOL resistors should not be used. The TR-CONTROL-6 is capable of supporting 3 Class A NACs. The TR-CONTROL-6 will only respond at the base address, base address +2, and base address +4 (assuming no addresses have been disabled).

TABLE 2.

NAC#	(+) CONNECTIONS	(-) CONNECTIONS
+0	+0 NAC+, +1 NAC+, Notification Appliance +	+0 NAC-, +1 NAC-, Notification Appliance-
+2	+2 NAC+, +3 NAC+, Notification Appliance +	+2 NAC-, +3 NAC-, Notification Appliance-
+4	+4 NAC+, +5 NAC+, Notification Appliance +	+4 NAC-, +5 NAC-, Notification Appliance-

POWER SUPPLY WIRING AND SUPERVISION

Table 3 gives an overview of how the power connectors, T0-T5 and T10-T15, are interconnected by the circuit board (PCB). The external supply connection points, at T0-T5, are marked by PS- and PS+ on the PCB legend. Pin 1 is indicated by a dot next to T10-T16. The odd pins, on T10-T16, always connect to PS- pins (e.g. PS-, of the +0 NAC, is connected to T10-1 and T11-1). The even pins always connect to PS+ pins (e.g. PS+, of the +5 NAC, is connected to T15-4 and T16-2).

TABLE 3.

PS OR NAC NUMBER (TERMINAL / PINS)	TERMINAL / PINS
+0 (T0 - BOTTOM / PS- & PS+)*	T10 / 1 & 2, T11 / 1 & 2
+1 (T1 / PS- & PS+)	T11 / 3 & 4, T12 / 1 & 2
+2 (T2 / PS- & PS+)	T12 / 3 & 4, T13 / 1 & 2
+3 (T3 / PS- & PS+)	T13 / 3 & 4, T14 / 1 & 2
+4 (T4 / PS- & PS+)	T14 / 3 & 4, T15 / 1 & 2
+5 (T5 / PS- & PS+)	T15 / 3 & 4, T16 / 1 & 2

*Note: T0-TOP is reserved for SLC connections only. (See Figure 5.)

All power supplies, external to the cabinet (in which the TR-CONTROL-6 is housed), should be connected to T0-T5 which are suitable connectors for field wiring. The 1 x 4 terminal blocks, shown on page 1, should be used to make these connections.

All NACs can be wired to be powered by separate external supplies (figures 6 and 8 are typical), or a single supply (figures 7 and 9 are typical) can be shared among multiple NACs. If a supply is to be shared, between NACs wired to a common PCB, use the short power supply jumpers shown on page 1. The jumpers can be used on T11-T15. Refer to Table 4 for jumper functions. When multiple (2 or more) NAC circuits share a power supply, the wiring for the power supply must be in conduit and 20 feet (6 m) or less from the TR-CONTROL-6 board.

TABLE 4.

JUMPER LOCATION	NAC PAIR SHARING SUPPLY
T11*	+0 and +1
T12	+1 and +2
T13*	+2 and +3
T14	+3 and +4
T15*	+4 and +5

*NOTE: Jumpers must be placed on T11, T13 and T15 for all Class A applications.

A supply can be wired to be shared among multiple PCBs in the same cabinet. (Figure 10 is typical.) To share among multiple PCBs: use the long power supply jumpers (shown on page 1) to connect either T10 or T16, of one PCB, to either T10 or T16 of the other PCB.

An EOL relay must be used for every external power supply. (Figures 6-9 are typical.) The EOL relay coil should always be connected at the external power supply input of the module which is connected to the ends of the wires which are farthest from the power supply. The EOL relay contacts should always be connected in series with the NAC wiring of the same module. The EOL relay coil should be connected across the PS+ (red wire) and PS- (black wire) if it is connected at T0 - T5. The EOL relay coil should be connected across adjacent pins (red - even pin#, black - odd pin#), of the same connector, if T10 - T16 are used. If the supply is an audio amplifier then the points, where the EOL relay coil would normally be connected, should be connected to the amplifier supervision EOL device. (Figure 10 is typical.)

All wiring must be in accordance with the NEC, NFPA 72 and all other applicable codes and standards. All external power supplies must be voltage regulated with battery back-up. All external power supplies, audio amplifiers, EOL relays, and notification appliances must be UL listed for fire protection signaling applications.

FIGURE 6. EXAMPLE OF CLASS B NAC CONFIGURATION WITH A SINGLE SUPPLY DEDICATED TO A SINGLE NAC

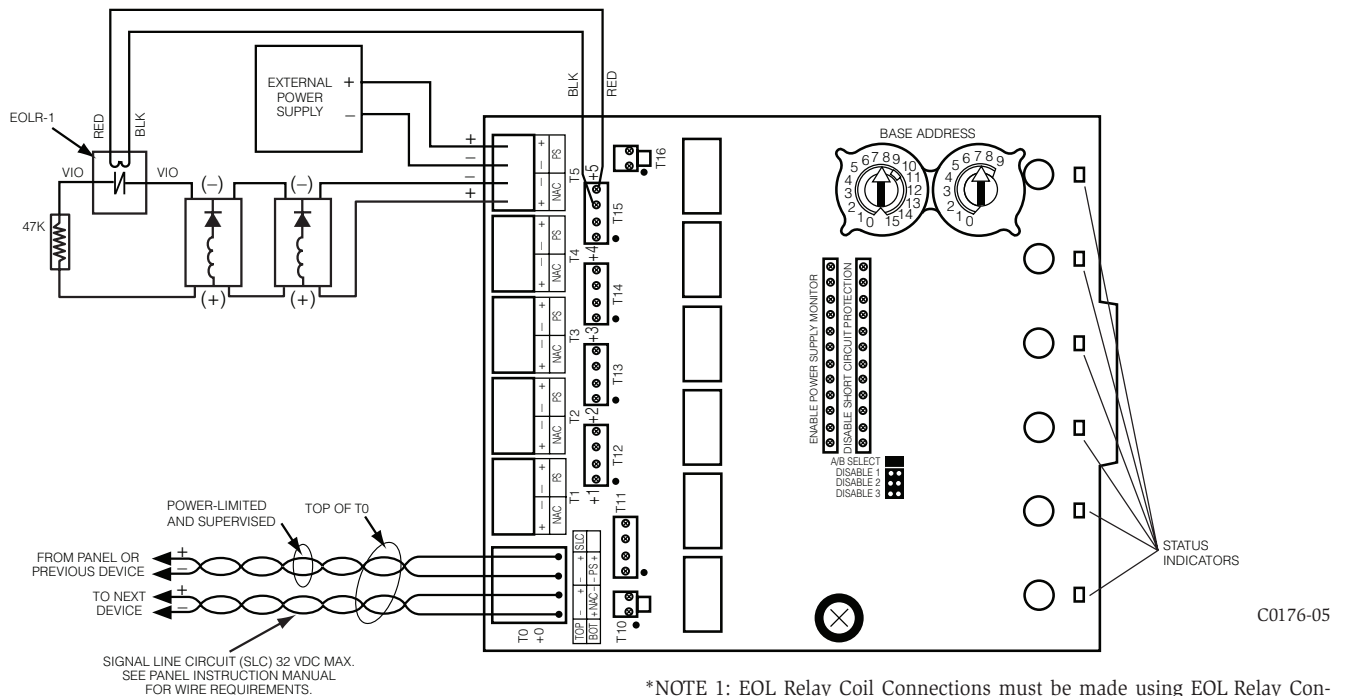

*NOTE 1: EOL Relay Coil Connections must be made using EOL Relay Connector Assemblies on T10-T16 in event that all NACs on the PCB have dedicated supplies.

FIGURE 7. EXAMPLE OF CLASS B NAC CONFIGURATION WITH A SINGLE SUPPLY SHARED BY 2 NACS

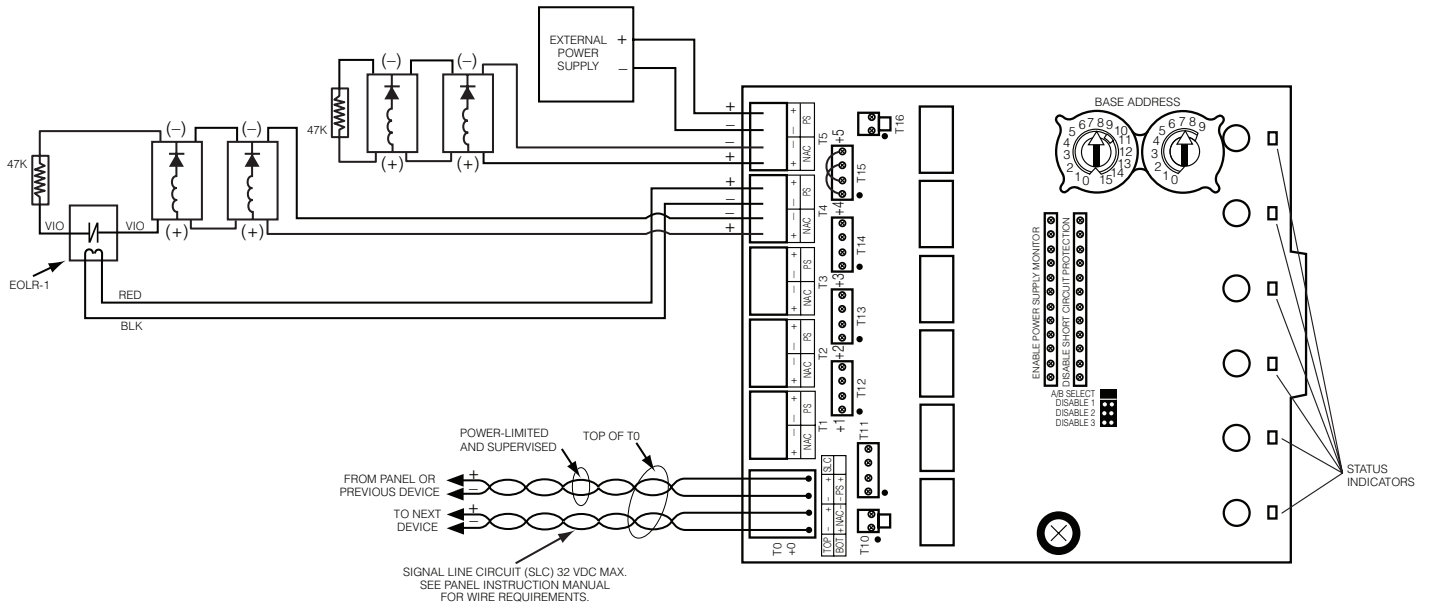

C0175-05

FIGURE 8. EXAMPLE OF CLASS A NAC CONFIGURATION WITH A SINGLE SUPPLY DEDICATED TO A SINGLE NAC

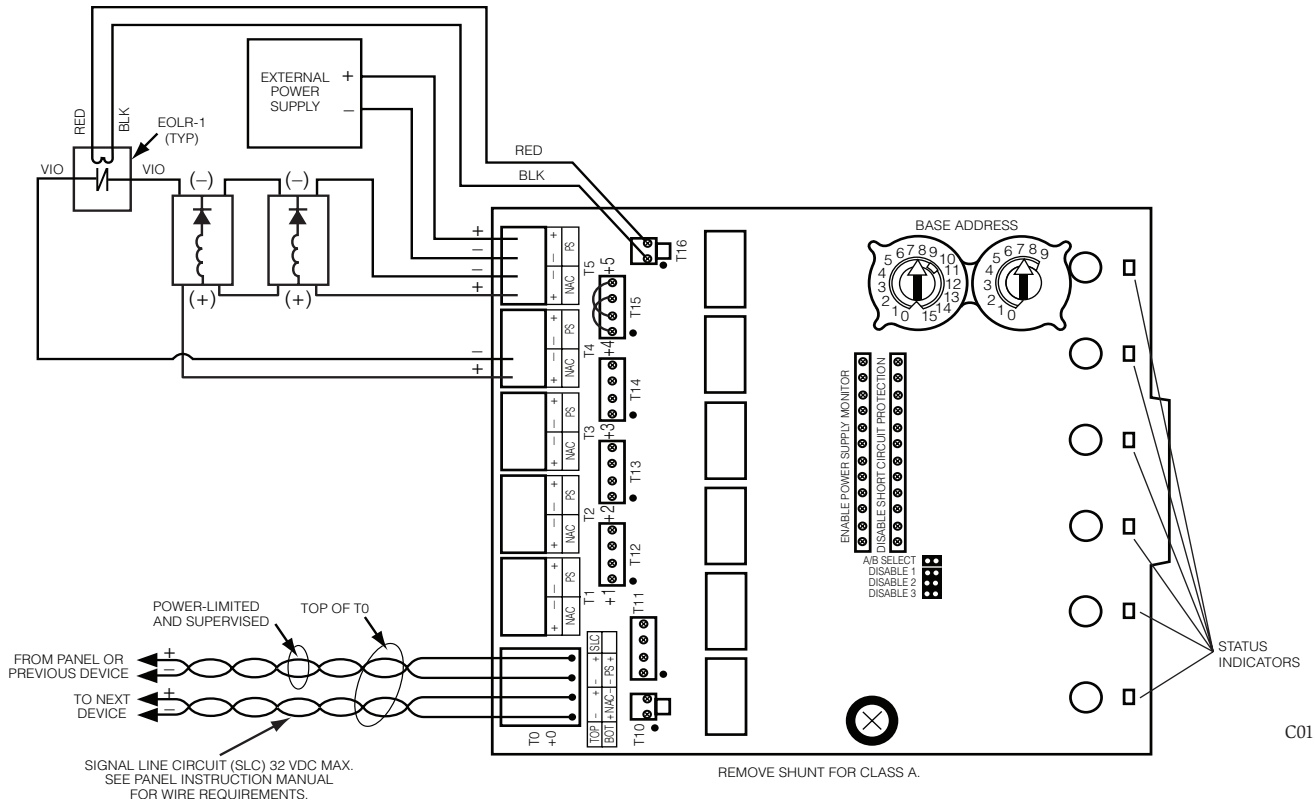

C0177-04

FIGURE 9. EXAMPLE OF CLASS A NAC CONFIGURATION WITH A SINGLE SUPPLY SHARED BY 2 NACS

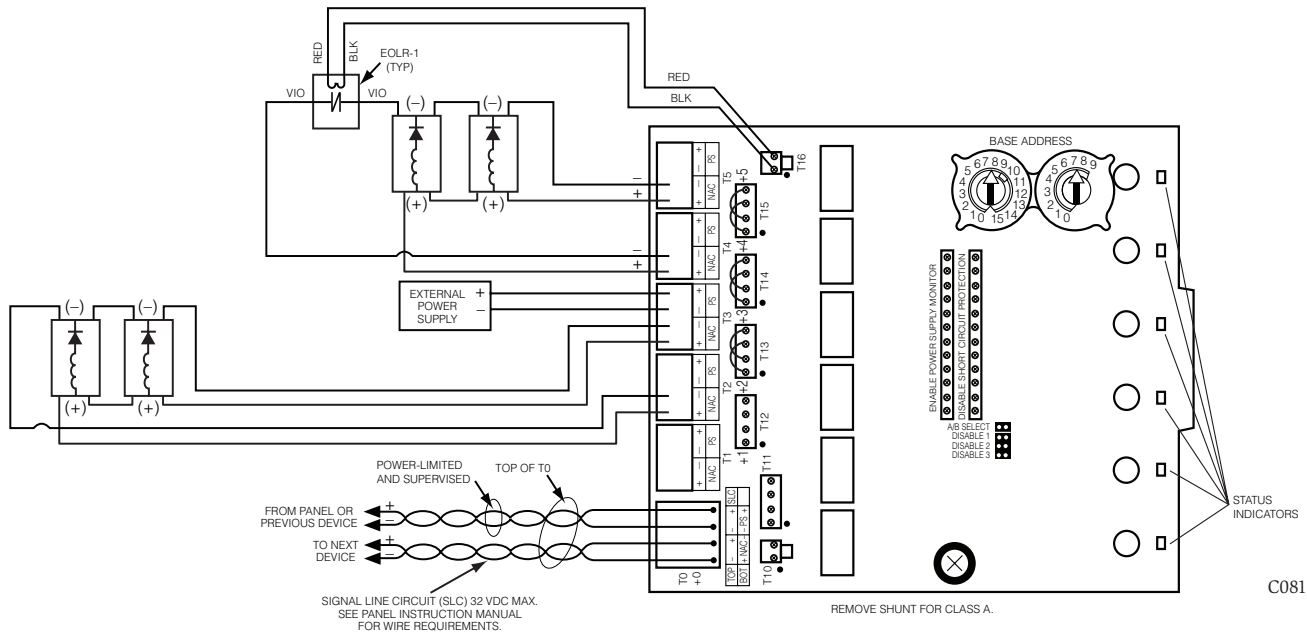

C0819-04

FIGURE 10. EXAMPLE OF MULTIPLE BOARDS SHARING SAME EXTERNAL SUPPLY

Supply is shared by NACs +0 and +1 (on PCB 1) as well as +3, +4, and +5 (on PCB 2). Refer to figures 9–12 for typical NAC wiring. Make certain lip on long power supply jumper engages retaining tab on T10 or T16 as shown in View A-A.

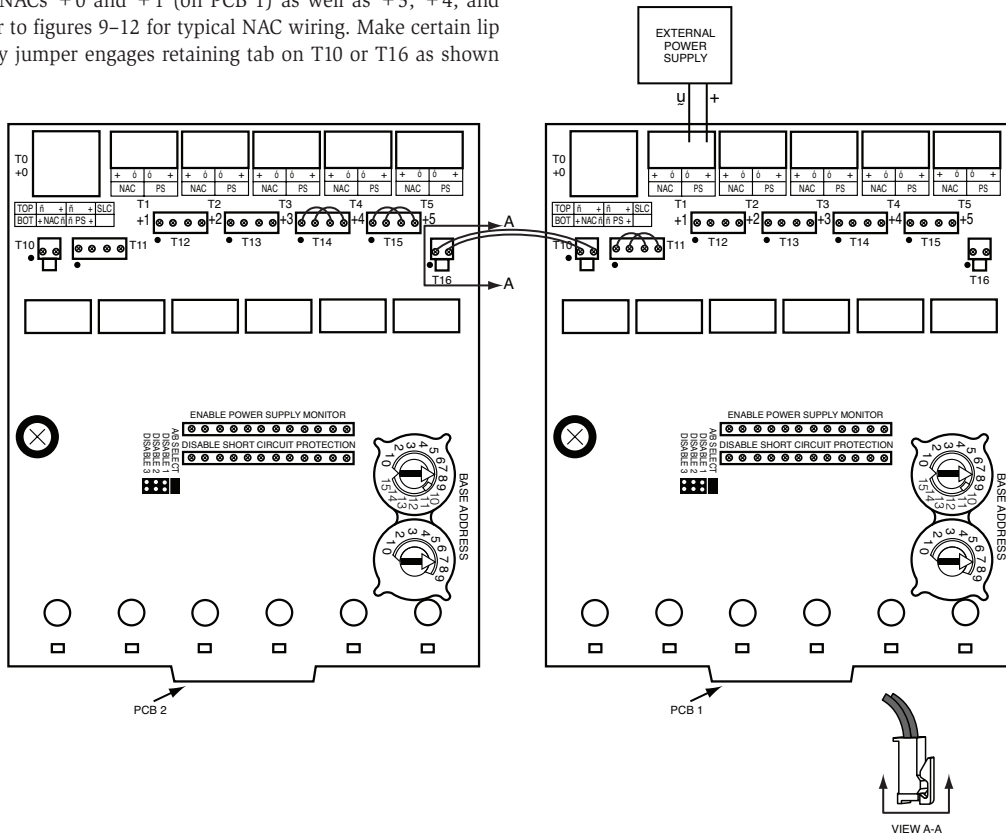

C0247-03

FCC STATEMENT

This device complies with part 15 of the FCC Rules. Operation is subject to the following two conditions: (1) This device may not cause harmful interference, and (2) this device must accept any interference received, including interference that may cause undesired operation.

NOTE: This equipment has been tested and found to comply with the limits for a Class B digital device, pursuant to Part 15 of the FCC Rules. These limits are designed to provide reasonable protection against harmful interference in a residential installation. This equipment generates, uses and can radiate radio frequency energy and, if not installed and used in accordance with the instructions, may cause harmful interference to radio communications. However, there is no guarantee that interference will not occur in a particular installation. If this equipment does cause harmful interference to radio or television reception, which can be determined by turning the equipment off and on, the user is encouraged to try to correct the interference by one or more of the following measures:

- Reorient or relocate the receiving antenna.
- Increase the separation between the equipment and receiver.
- Connect the equipment into an outlet on a circuit different from that to which the receiver is connected.
- Consult the dealer or an experienced radio/TV technician for help.

DEVICE AND SYSTEM SECURITY

Before installing this product ensure that the tamper seal on the packaging is present and unbroken and the product has not been tampered with since leaving the factory. Do not install this product if there are any indications of tampering. If there are any signs of tampering the product should be returned to the point of purchase.

It is the responsibility of the system owner to ensure that all system components, i.e. devices, panels, wiring etc., are adequately protected to avoid tampering of the system that could result in information disclosure, spoofing, and integrity violation.